

HY-GD550-TD-803 Parts list

1

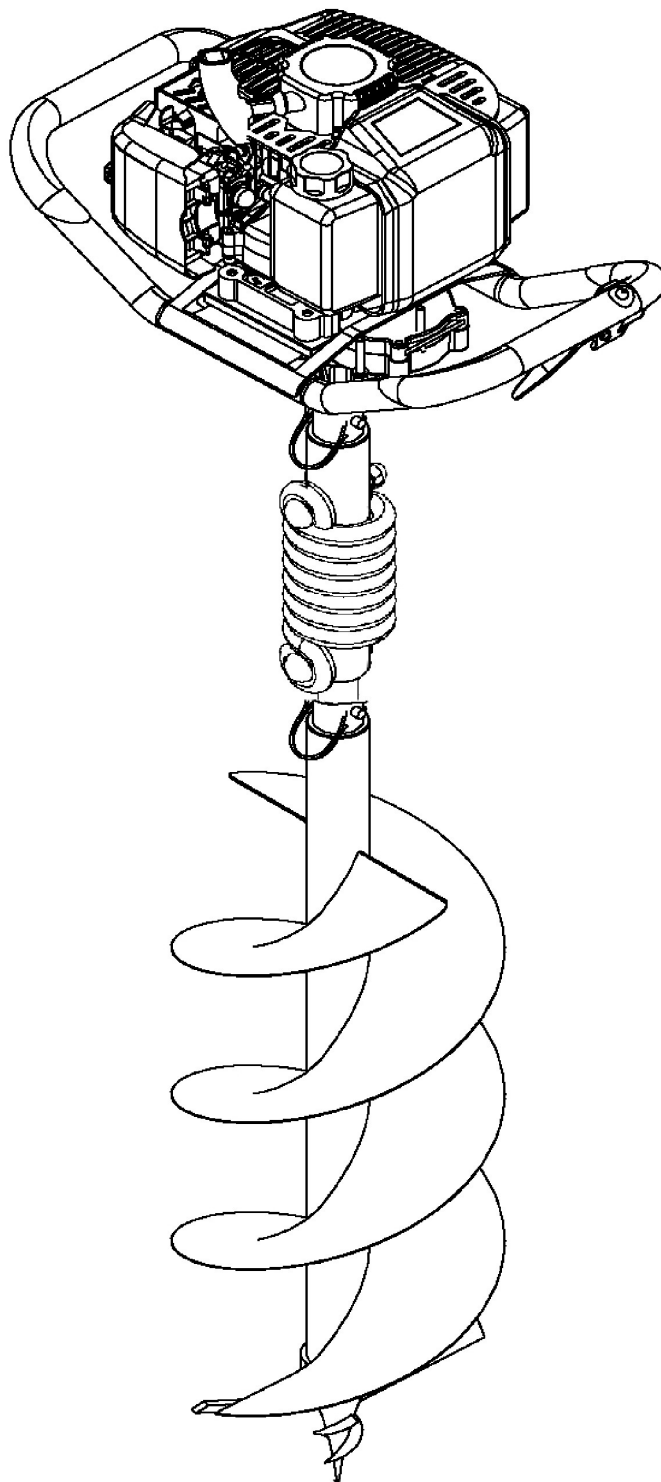
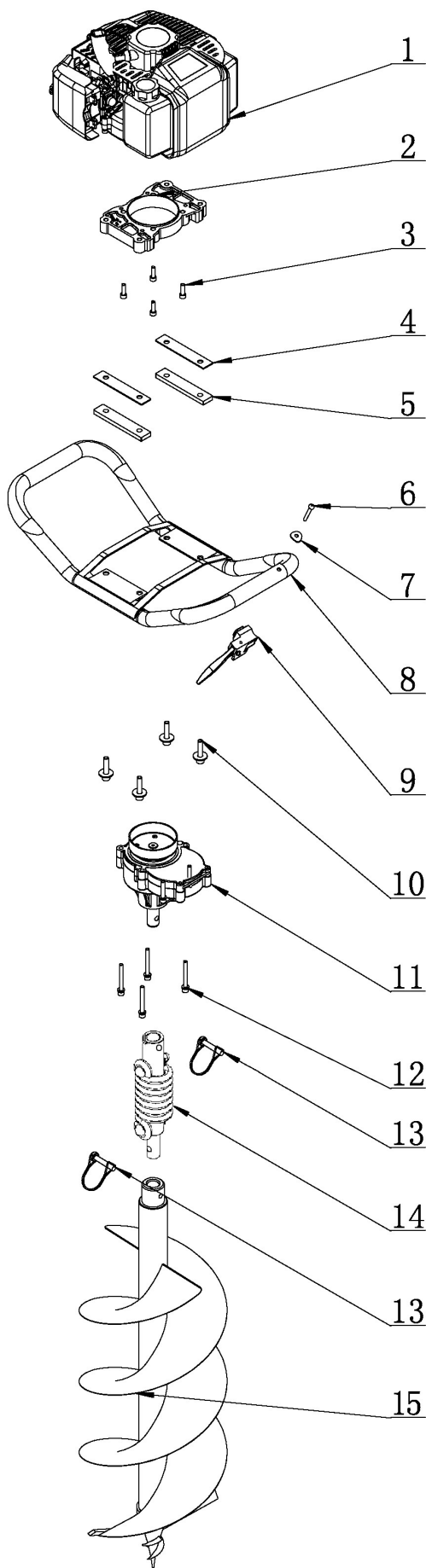

ERP Code (1)	No.	物料名称	Name	Qty	Us\$	Qty	Sum
03.01.02.02.011		HY-GD550-TD-803地钻裸机	Ground drill machine	1	pcs		
03.06.002	1	HY-1E44F-5-TD动力成品 (地钻)	1E44F-5-TD Ground drill engine	1	pcs		

04.01.053.0001	2	过渡板:二代	Connection board	1	pcs			
05.04.0459	3	螺丝:黑镍内六角不组合	Screw M6*20	4	pcs			
04.01.057.0007	4	地钻减震条:铁质	Metal AVS	2	pcs			
04.01.057.0004	5	地钻减震条:橡胶	Rubber AVS	2	pcs			
05.04.1404	6	螺丝:白色十字盘头不组合	Screw M5*40	1	pcs			
05.06.0901	7	垫片:伞型	Umbrella metal gasket M6	1	pcs			
04.03.025.0009	8	803架子总成/3020红	Handle	1	pcs			
04.01.045.0027	9	熄火开关总成:简易防水	ON/OFF trigger assy	1	pcs			
05.04.0201	10	螺丝:黑镍内六角组合(大垫片)	Screw M8*35	4	pcs			
03.10.0100	11	地钻齿轮箱总成:二代	Gear case assy (1-19)	1	pcs			
05.04.0019	12	螺丝:黑镍内六角组合	Screw M6*50	4	pcs			
05.03.0202	13	D型销	D Type clip	1	pcs			
03.19.0001	14	弹簧适配器	Spring reducer	1	pcs			
	15	PT-S 钻头(φ60mm, L 800mm)	HY-PT-S Auger bit (φ60* L 800mm)	1	pcs			
		PT-S 钻头(φ80mm, L 800mm)	HY-PT-S Auger bit (φ80* L 800mm)	1	pcs			
		PT-S 钻头(φ100mm, L 800mm)	HY-PT-S Auger bit (φ100* L 800mm)	1	pcs			
		PT-S 钻头(φ120mm, L 800mm)	HY-PT-S Auger bit (φ120* L 800mm)	1	pcs			
		PT-S 钻头(φ150mm, L 800mm)	HY-PT-S Auger bit (φ150* L 800mm)	1	pcs			
		PT-S 钻头(φ200mm, L 800mm)	HY-PT-S Auger bit (φ200* L 800mm)	1	pcs			
		PT-S 钻头(φ250mm, L 800mm)	HY-PT-S Auger bit (φ250* L 800mm)	1	pcs			
		PT-S 钻头(φ300mm, L 800mm)	HY-PT-S Auger bit (φ300* L 800mm)	1	pcs			
		PT-S 钻头(φ400mm, L 800mm)	HY-PT-S Auger bit (φ400* L 800mm)	1	pcs			
		PT-S 钻头(φ500mm, L 800mm)	HY-PT-S Auger bit (φ500* L 800mm)	1	pcs			
		PT-S 钻头(φ600mm, L 800mm)	HY-PT-S Auger bit (φ600* L 800mm)	1	pcs			
		PT-S 钻头(φ700mm, L 800mm)	HY-PT-S Auger bit (φ700* L 800mm)	1	pcs			
		15	PT-D 钻头(φ60mm, L 800mm)	HY-PT-D Auger bit (φ60* L 800mm)	1	pcs		
			PT-D 钻头(φ80mm, L 800mm)	HY-PT-D Auger bit (φ80* L 800mm)	1	pcs		
	PT-D 钻头(φ100mm, L 800mm)		HY-PT-D Auger bit (φ100* L 800mm)	1	pcs			
	PT-D 钻头(φ120mm, L 800mm)		HY-PT-D Auger bit (φ120* L 800mm)	1	pcs			
	PT-D 钻头(φ150mm, L 800mm)		HY-PT-D Auger bit (φ150* L 800mm)	1	pcs			
	PT-D 钻头(φ200mm, L 800mm)		HY-PT-D Auger bit (φ200* L 800mm)	1	pcs			
	PT-D 钻头(φ250mm, L 800mm)		HY-PT-D Auger bit (φ250* L 800mm)	1	pcs			
	PT-D 钻头(φ300mm, L 800mm)		HY-PT-D Auger bit (φ300* L 800mm)	1	pcs			
	PT-D 钻头(φ400mm, L 800mm)		HY-PT-D Auger bit (φ400* L 800mm)	1	pcs			
	PT-D 钻头(φ500mm, L 800mm)		HY-PT-D Auger bit (φ500* L 800mm)	1	pcs			
	PT-D 钻头(φ600mm, L 800mm)	HY-PT-D Auger bit (φ600* L 800mm)	1	pcs				
	PT-D 钻头(φ700mm, L 800mm)	HY-PT-D Auger bit (φ700* L 800mm)	1	pcs				

2

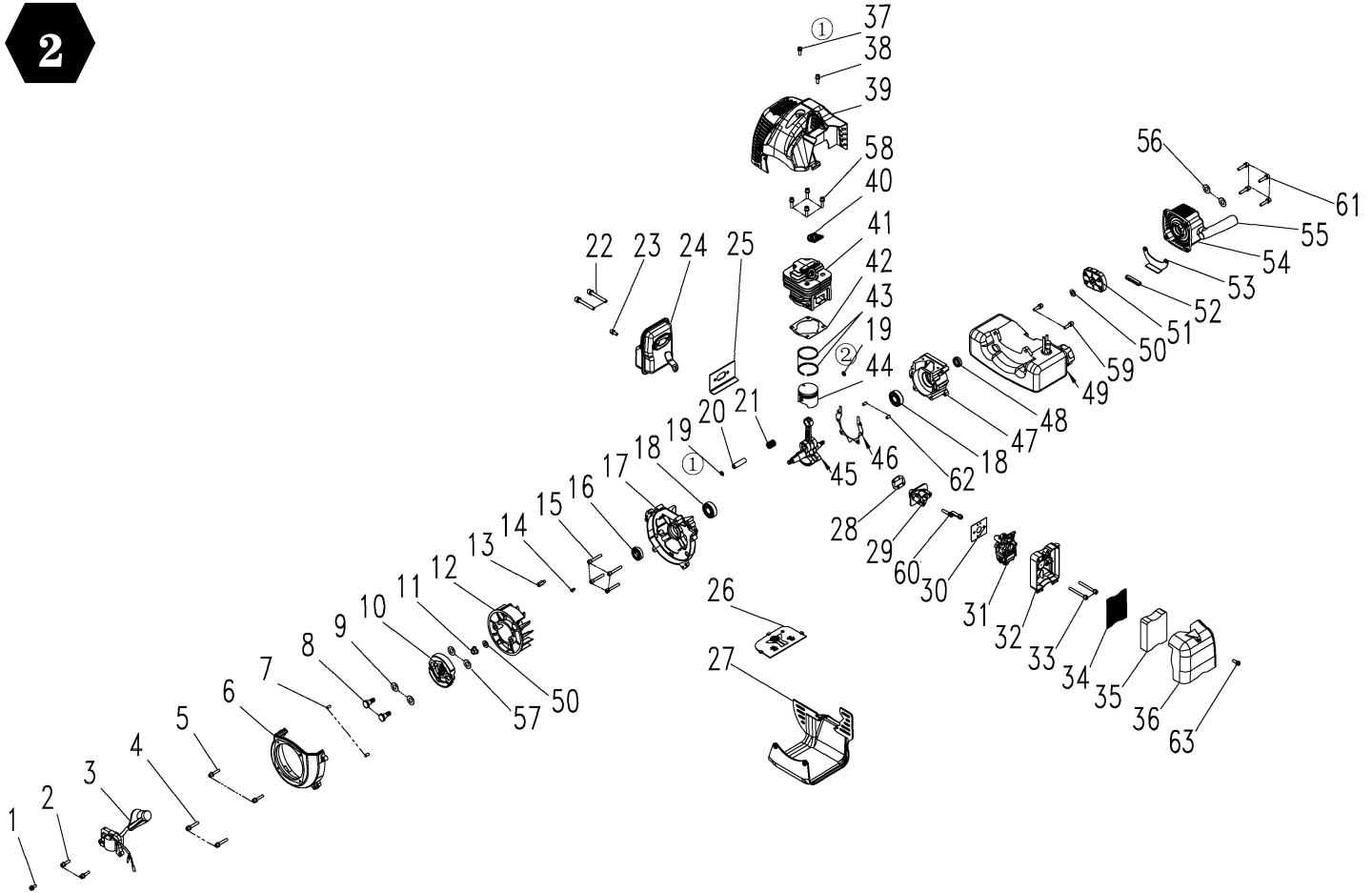

ERP Code (2)	No.	物料名称	Name	Qty	Us\$	Qty	Sum
05.04.0703	1	螺丝:黑镍十字盘头组合	Screw M5*14 +	1	pcs		
05.04.0005	2	螺丝:黑镍内六角组合	Screw M5*25	2	pcs		

04.01.012.0002	3	点火器:1E40F-5	Ignition	1	pcs		
05.04.0007	4	螺丝:黑镍内六角组合	Screw M5*30	2	pcs		
05.04.0006	5	螺丝:黑镍内六角组合	Screw M5*25	2	pcs		
04.01.054.0001	6	边盖:1E40/44F-5	Sider cover	1	pcs		
05.03.0002	7	定位销:边盖处	Nut M5*10	2	pcs		
05.04.2031	8	螺丝:台阶螺丝	Screw Φ9.5*M8*24	2	pcs		
05.06.1200	9	波形垫片	Waveform gasket M10*17	2	pcs		
04.01.020.0001	10	离合器蹄块:粉末/1E40F/44F-5	Clutch	1	pcs		
05.05.0001	11	法兰螺母:飞轮/黑镍螺母	Screw nut M8*1.25	1	pcs		
04.01.001.0001	12	磁飞轮:1E40/44F-5	Fly wheel	1	pcs		
05.04.2011	13	螺丝:单头六角柱/内径*六角柱长度+螺纹长度	Screw M8*13.6+6	1	pcs		
05.09.0001	14	半圆键:黑色	Half key 3*13	1	pcs		
05.04.0008	15	螺丝:黑镍内六角组合	Screw M5*35	4	pcs		
04.01.043.0001	16	油封:1E40/44F-5	Oil seal 15*30*7	1	pcs		
04.01.052.0001	17	箱体:1E40/44F-5/小	Crank shaft case (A)	1	pcs		
05.02.0003	18	轴承:6202P5Z3/48F/44-5/40-5	Bearing 6202	2	pcs		
04.01.010.0008	19	活塞卡簧:1E40F/44F/48F型	Piston nut clip	2	pcs		
04.01.007.0002	20	活塞销:1E44F-5	Piston nut	1	pcs		
04.01.009.0002	21	滚针:1E44F-5活塞	Needle bearing 10*14*16	1	pcs		
05.04.0021	22	螺丝:黑镍内六角组合	Screw M6*60	2	pcs		
05.04.0003	23	螺丝:黑镍内六角组合	Screw M5*14	1	pcs		
04.01.051.0002	24	消音器:1E40F-5	Muffler	1	pcs		
04.01.013.0001	25	消音器垫片:1E40/44F-5	Muffler gasket	1	pcs		
04.02.002.0200	26	挡风板:TD款1E40F-5	Blocking debris board	1	pcs		
04.01.048.0150	27	油壶保护座:塑料全包	Fuel tank keeper	1	pcs		
04.01.016.0001	28	进气管垫片:1E40/44F-5	Air entrence gasket	1	pcs		
04.01.056.0001	29	进气管:1E40/44F-5	Air entrence	1	pcs		
03.07.01.0001		黑色单向易启动器总成(54-55)	Supper easy starter assy	1	pcs		
03.08.0001		空滤器总成:TU/TV款	Air filter assy	1	pcs		
04.01.014.0001	30	化油器垫片:1E40/44-5	Carburetor gasket	1	pcs		
04.01.033.0001	31	化油器:1E40F/44F-5	Carburetor	1	pcs		
04.01.025.0001	32	空滤器底盘:TU/TV款	Air filter plate	1	pcs		
05.04.0011	33	螺丝:黑镍内六角组合	Screw M5*55	2	pcs		
04.01.027.0001	34	空滤器网片:TU/TV款	Air filter grid board	1	pcs		
04.01.024.0001	35	空滤器海绵:TU/TV款	Air filter sponge	1	pcs		
04.01.026.0001	36	空滤器上盖:TU/TV款	Air filter cover	1	pcs		
05.04.0704	37	螺丝:黑镍十字盘头组合	Screw M5*16 +	1	pcs		
05.04.0004	38	螺丝:黑镍内六角组合	Screw M5*16	1	pcs		
04.02.001.0251	39	缸体罩:TD款1E40F-5/地钻	Cylinder cover	1	pcs		
04.01.003.0001	40	火花塞:L7T/华达	Spark plug	1	pcs		
04.01.005.0002	41	气缸:44-5/Dia44mm	Cylinder	1	pcs		
04.01.015.0001	42	气缸垫片:1E40/44F-5	Cylinder gasket	1	pcs		
04.01.008.0002	43	活塞环:1E44F-5	Piston spring	2	pcs		
04.01.006.0002	44	活塞:1E44F-5	Piston	1	pcs		
04.01.002.0001	45	曲轴:1E44F-5	Crank shaft	1	pcs		
04.01.017.0001	46	箱体垫片:1E40/44F-5	Crank shaft case gasket	1	pcs		
04.01.052.0003	47	箱体:1E40/44F-5/大	Crank shaft case (B)	1	pcs		
04.01.043.0002	48	油封:1E40/44F-5/G45/1E34F	oil seal 12*22*7	1	pcs		
04.02.008.0001	49	油壶:1E40F-5/三根管/侧口/地钻油壶	Fuel tank assy	1	pcs		
05.06.0006	50	平垫片	Flat gasket (Steel) M8*18*1.5	2	pcs		
04.01.022.0001	51	启动器拨盘:1E40F-5/易启动/双拨爪	Starter plate	1	pcs		
04.01.057.0002	52	油壶压板减震:40F-5	Ruber AVS - fuel tank presure	1	pcs		
04.01.050.0001	53	油壶压板:40-5/44-5	Fuel tank presure	1	pcs		
04.01.011.0100	54	单向易启动器:1E40/44F-5	Supper easy starter (W/T handle	1	pcs		
04.02.011.0002	55	启动器手柄	Starter handle (R+B)	1	pcs		
04.03.041.0013	56	弹簧:平衡气嘴固定钩/地钻用	Spring arm	1	pcs		
05.06.0001	57	平垫片	Flat gasket (Steel) M8*16*2.0	2	pcs		
05.04.0306	58	螺丝:黑色内六角组合	Screw M5*20 12.9D	4	pcs		
05.04.0005	59	螺丝:黑镍内六角组合	Screw M5*20	2	pcs		
05.04.0006	60	螺丝:黑镍内六角组合	Screw M5*25	2	pcs		
05.04.0006	61	螺丝:黑镍内六角组合	Screw M5*25	4	pcs		
05.03.0002	62	定位销:1E40/44F箱体	Nut M5*10	2	pcs		
05.04.0704	63	螺丝:黑镍十字盘头组合	Screw M5*16 +	1	pcs		

3

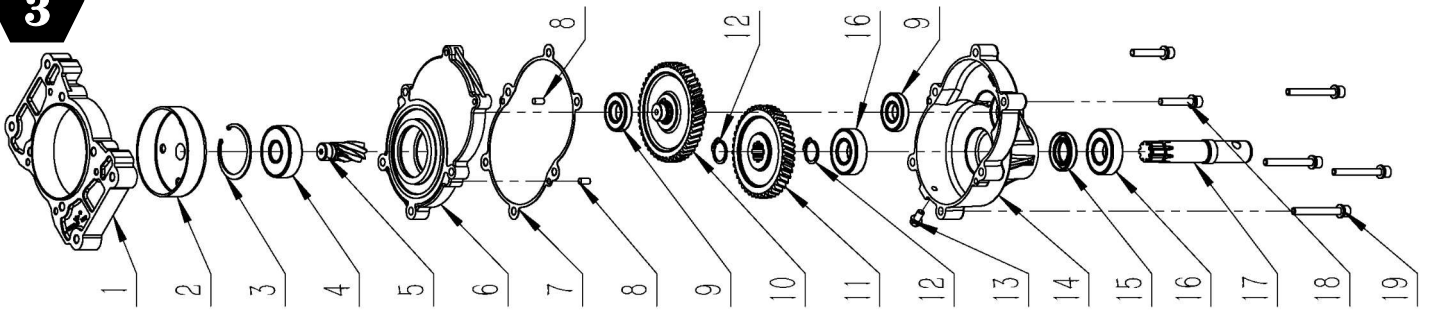

ERP Code (3)	No.	物料名称	English name	Qty	Us\$	Qty	Sum
03.10.0100		地钻齿轮箱总成:二代	Gear case assy (1-19)	1	pcs		
04.01.053.0001	1	过渡板:二代	Connection board	1	pcs		
04.01.035.0001	2	地钻被动盘:一/二代	Clutch drum	1	pcs		
05.07.0004	3	卡簧:孔47MM卡簧	spring clip 47mm	1	pcs		
05.02.0010	4	轴承:6303-2RS(人本)	Bearing 6303-2RS	1	pcs		
04.04.006.0001	5	输入轴:二代/斜齿	Input shaft	1	pcs		
04.01.052.0301	6	箱体:地钻上箱体/二代	Up cover	1	pcs		
04.01.017.0003	7	箱体垫片:地钻齿轮箱用/一代/二代	Gear case agasket	1	pcs		
05.03.0002	8	定位销:1E40/44F箱体	Locate nut 5*10	2	pcs		
05.02.0012	9	轴承:R10	Bearing R10	2	pcs		
04.04.007.0003	10	双联齿轮:一代/二代通用/斜齿	Double gearwheel	1	pcs		
04.04.007.0004	11	输出齿轮:一代/二代通用/花键	Output gearwheel	1	pcs		
05.07.0003	12	卡簧:轴19MM卡簧	Spring clip 19mm	2	pcs		
05.04.2012	13	螺丝:法兰白色/注油嘴用	Screw M6*10	1	pcs		
04.01.052.0302	14	箱体:地钻下箱体/二代	Down cover	1	pcs		
04.01.043.0010	15	油封:地钻	Oil seal 20*35*7	1	pcs		
05.02.0013	16	轴承:6004-2RS	Bearing 6004-2RS	2	pcs		
04.04.004.0010	17	输出轴:一代/二代通用/花键	Output shaft	1	pcs		
05.04.0017	18	螺丝:黑镍内六角组合	Screw M6*38	2	pcs		
05.04.0019	19	螺丝:黑镍内六角组合	Screw M6*50	4	pcs		

4

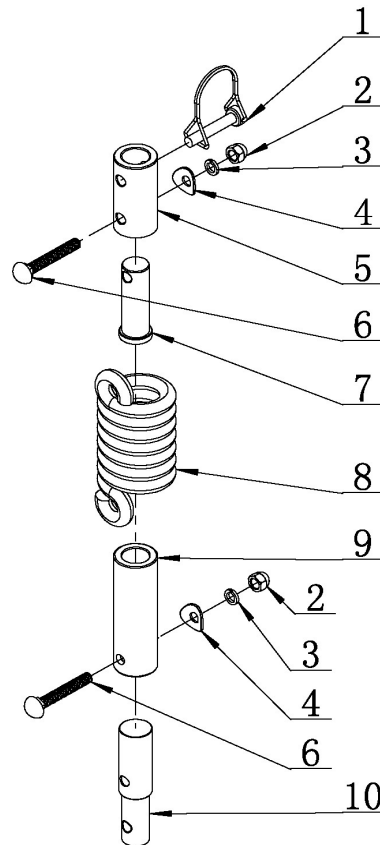
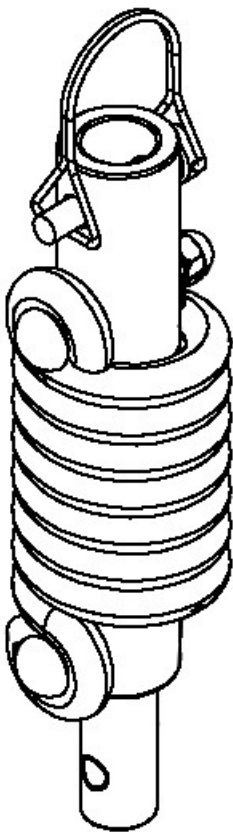

ERP Code (4)	No.	物料名称	English name	Qty	Us\$	Qty	Sum
03.19.0001		弹簧适配器:20MM/20MM/配D型销/黑色	Spring reducer assy (1-10)	1	pcs		
05.03.0202	1	D型销	D Type clip	1	pcs		
05.05.0603	2	螺母:盖帽	Screw nut M8	2	pcs		
05.06.0600	3	弹垫片	Spring gasket	2	pcs		

05.06.0900	4	垫片:伞型	Umbrella metal gasket M8.5*20*1	2	pcs			
04.03.042.0004	5	弹簧组件:短套	B Casing	1	pcs			
05.04.2042	6	螺丝:白色/组弹簧适配器用	Screw M8*55	2	pcs			
04.03.042.0002	7	弹簧组件:短轴	B shaft	1	pcs			
04.03.041.0002	8	弹簧:弹簧适配器用/黑色	Spring	1	pcs			
04.03.042.0003	9	弹簧组件:长套	A Casing	1	pcs			
04.03.042.0001	10	弹簧组件:长轴	A shaft	1	pcs			
ERP Code (5)	No.	物料名称	English name	Qty	Us\$	Qty	Sum	
04.02.012.0002		漏斗:带滤网	Filter of funnel	1	pcs			
04.02.015.0001		配比壶:1.5L/小口中档	Match ratio tank	1	pcs			
05.01.0001		扳手:开口/高端	Open wrench M8/M10	1	pcs			
05.01.0401		扳手:套筒/一字架/高端	Socket wrench M17/19*-	1	pcs			
05.01.0800		扳手:两用螺丝刀/十/一/高端	Screw driver +*-	1	pcs			
05.01.0601		扳手:内六角加长	Allen wrench M5	1	pcs			
05.01.0602		扳手:内六角加长	Allen wrench M6	1	pcs			
06.01.0002		说明书:地钻/中性英文	Manual	1	pcs			
06.03.0001		不干胶:英文油壶配比标	Sticker (Fuel tank)	1	pcs			
06.03.0002		不干胶:英文配比壶标	Sticker (Match ratio tank)	1	pcs			
06.03.0005		不干胶:地钻架子警告标/通用	Warning sticker	1	pcs			
06.03.0025		不干胶:防火标/通用	Fireproof sticker	1	pcs			
06.03.0027		不干胶:防烫标/通用	Prevent burns sticker	1	pcs			
06.03.0028		不干胶:启动提示标/通用	Start notice stiker	1	pcs			
06.04.04**		牛皮纸纸箱:	Carton	1	pcs			
06.07.00**		水晶标 英文图标	Sticker on starter	1	pcs			
06.08.00**		工具包:地钻	Tool kits bag	1	pcs			