

Loncin

LC2V78F-1

Service Manual



Loncin Industries Ltd

Contents

Part I Technical specifications	1
1-1 Introduction of the engine	2
1-2 Product parameters	3
1-3 Gasoline engine dimensions (boundary and mounting dimensions).....	4
1-4 PTO assembly drawing.....	5
1-5 Wiring diagram	6
Part II Description of maintenance.....	7
2-1 Matters needing attention during maintenance	7
2-2 Maintenance standards.....	9
2-3 Tightening torque values of fasteners	10
2-4 Special tools.....	11
2-5 Diagnosis	13
Part III Maintenance	18
3-1 Maintenance schedule	18
3-2 Oil change.....	19
3-3 Check of oil alarm device	20
3-4 Maintenance of air filter.....	21
3-5 Maintenance of muffler.....	22
3-6 Cleaning of fuel filtering system	23
3-7 Maintenance of spark plug.....	23
3-8 Adjustment of carburetor (idle speed)	24
3-9 Adjustment of valve clearance	25
3-10 Adjustment of throttle lever	26
Part IV Disassemble, check and repair	27
4-1 Air filter and muffler.....	27
4-2 Starter and control box.....	29
4-3 Carburetor.....	31
4-4 Cylinder head and valves	33
4-5 Piston, connection rod, and crankshaft.....	40
4-6 Crankcase cover and throttle	46
4-7 Flywheel, ignition coil and starter motor	47

1-1 Introduction of the engine	1-2 Product parameters	1-3 Gasoline engine dimensions (boundary and mounting dimensions)
	1-4 PTO assembly drawing	1-5 Schematic circuit diagram

1-1 Introduction of the engine

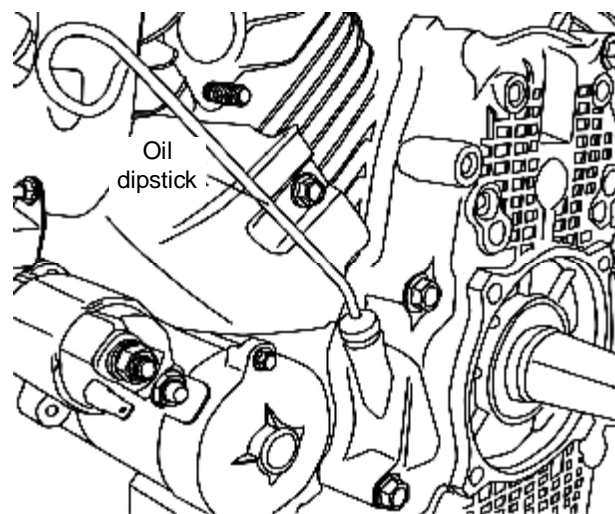
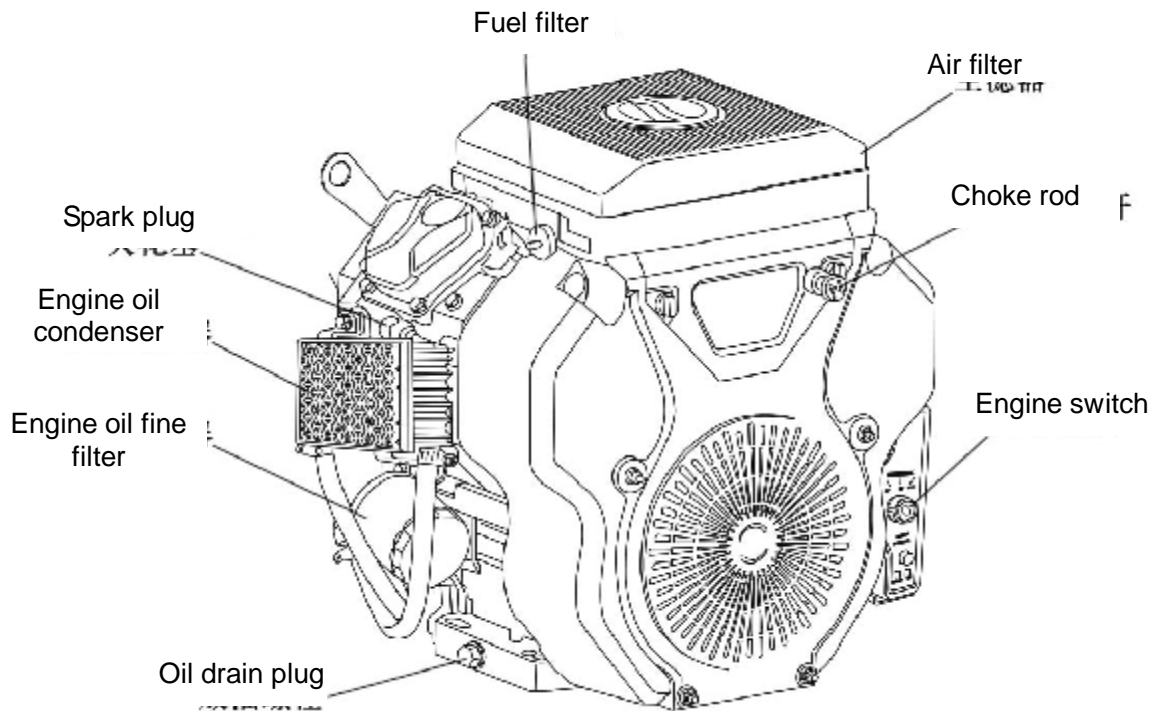

Air filter——protects the engine through filtering dust and other impurities in the air.

Spark plug——delivers the high voltage of the ignition coil into the engine's combustion chamber, and generates sparks by electric discharge between electric poles, to ignite the fuel-air mixture.

Muffler——prevents the engine noise from traveling, so as to lower noise of the exhaust system.

Fuel filter——connected between the fuel tank and carburetor by fuel pipes, serving to remove impurities in the fuel.

Engine oil condenser——receives the engine oil pumped into it by oil pump and cools the oil with its cooling fins, then lets oil condense and flow back to the crankcase.

Engine oil fine filter——lets engine oil flow through it to be filtered before it flows back into crankcase.

Choke rod——closes the choke before engine's cold starting, and the carburetor will deliver a very rich mixture to let the engine be easily startable. When the engine has warmed up, the choke rod shall be fully opened.

Engine switch——before starting the engine, the switch shall be put in the ON position; if you put the switch in the OFF position the engine will be shut down

Oil drain plug——by loosening out oil drain plug, all engine oil in the engine can be drained off, so that engine oil can be changed.

Oil dipstick——the tool to check engine oil level.

1-2 Product parameters

Engine model	LC2V78F-1
Engine type	V-type, double-cylinder
(KW/3600rpm) Max. power (KW/3600rpm)	14.7
Max.torque (N .m.rpm)	43.5/2500
Cylinder bore × stroke (mm)	78×71
Displacement (cc)	678
Engine oil capacity (L)	1.5
Compression ratio	8.5:1
Noise (≤7m)	70
Lubrication mode	Pressure + splash
Starting mode	Electric
Rotation direction of output shaft	Counterclockwise (seen from the end of output shaft)
Ignition system	T.C.I.
Air filter	Foam paper filter element
Minimum fuel consumption rate (g/KW.h)	≤360
Engine oil consumption rate (g/KW.h)	≤2
Idling speed (r/min)	1500±150
Boundary dimensions (L.W.H)	510X400X450
Net weight (kg)	43

1-3 Gasoline engine dimensions (boundary and mounting dimensions)

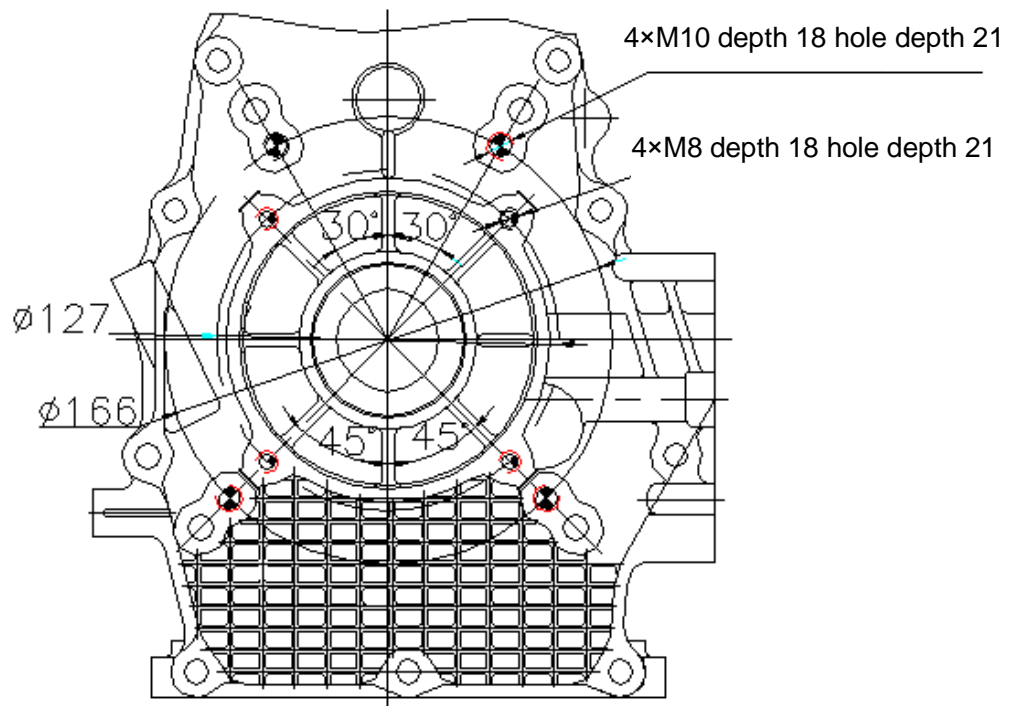
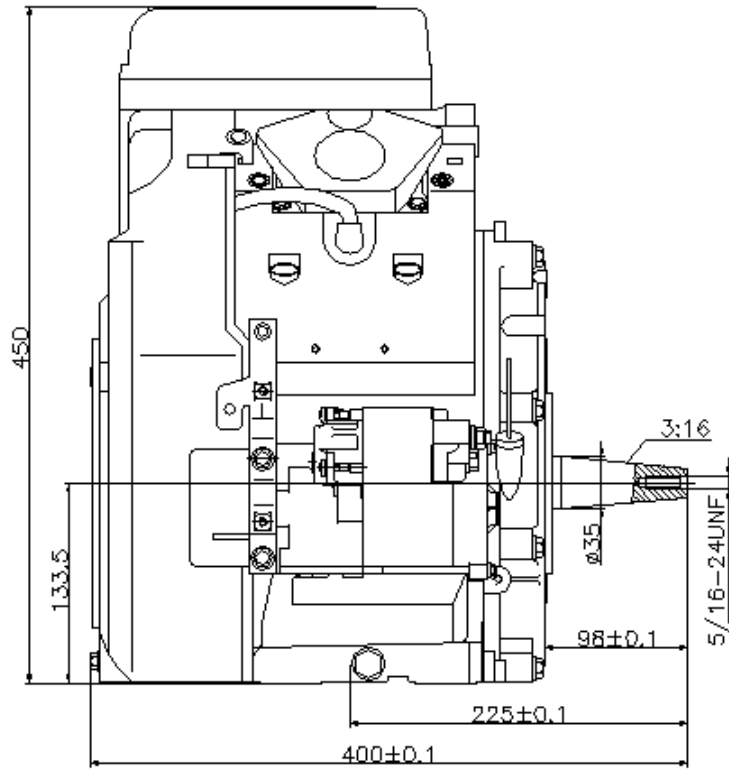

1-4 PTO assembly drawing

Shaft A/(C TYPE)

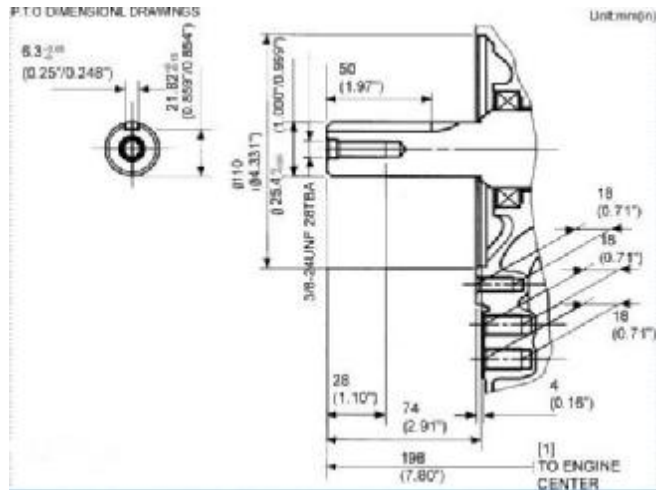

Shaft B/(B TYPE)

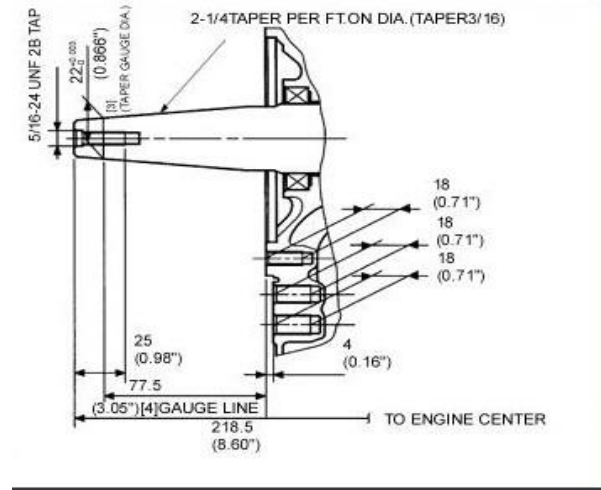

Shaft C/(C TYPE)

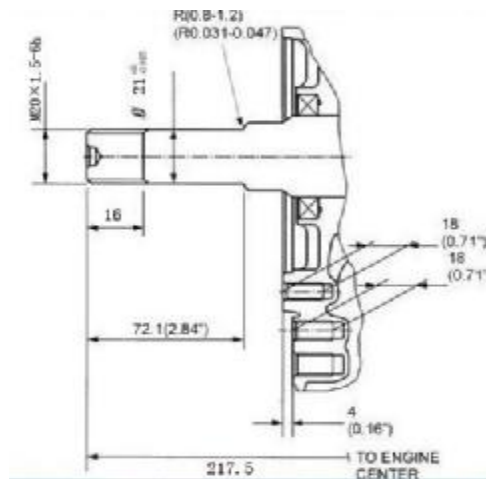

Shaft D/(D TYPE)

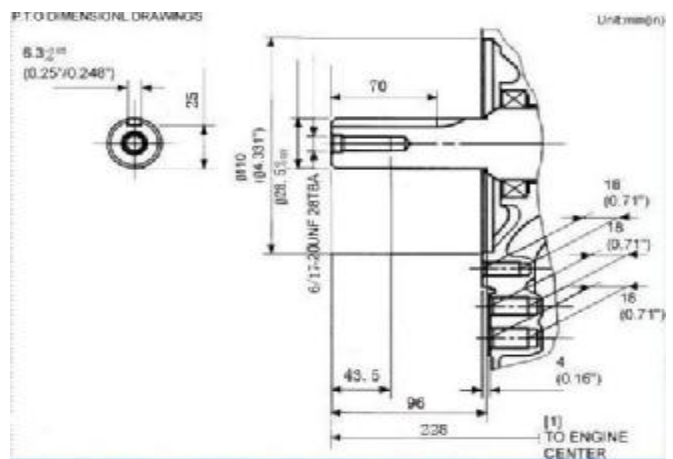

1-5.Schematic circuit diagram

Electric start, with engine oil alert device

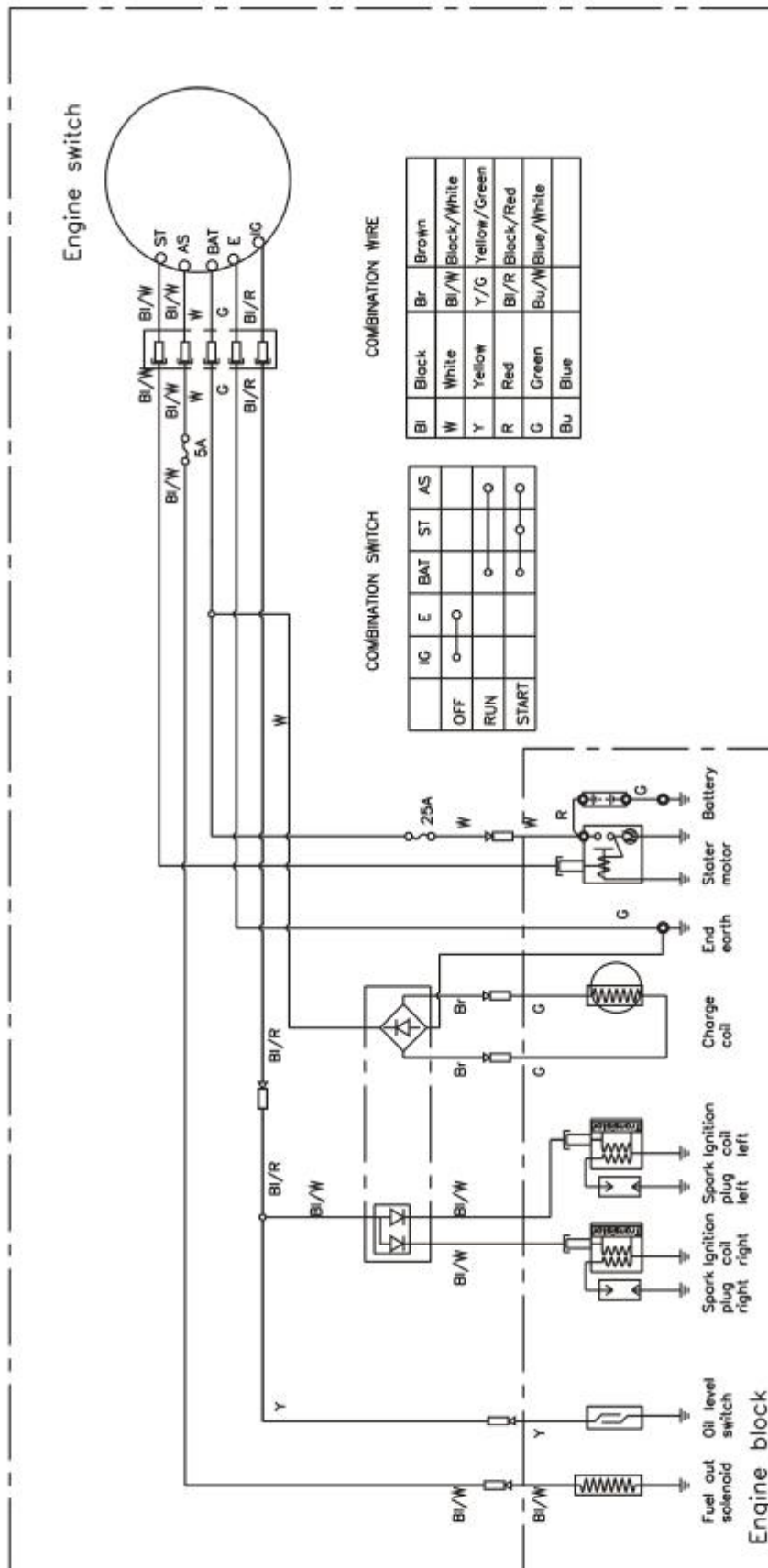

2-1 Matters needing attention during maintenance values of fasteners	2-2 Maintenance standards 2-4 Special tools	2-3 Tightening torque 2-5 Diagnosis
--	--	--

2-1 Matters needing attention during maintenance

1. Parts, oil and grease must be genuine LONCIN products or products designated by it

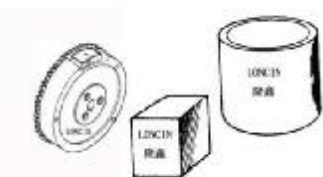

2. Work to be done with special tools must be done with such tools.



3. Gaskets, washers, and O-rings must be replaced after disassembling operation.



4. When fastening bolts, nuts and screws, follow the method of fastening from small diameter ones to big diameters ones, from inside to outside, and fastening diagonally, until the prescribed tightening torque values are reached.

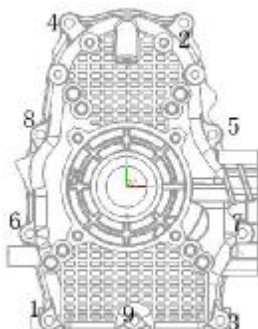

5. Parts shall be cleaned after being detached, when assembling them; engine oil must be applied on the sliding surfaces.

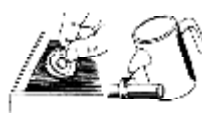

6. After assembly, tightness and operating state of each part must be checked.

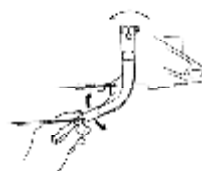

7. Engine must be stopped before being checked and maintained and work has to be done only when engine has adequately cooled, or scalding or other accidents may occur.

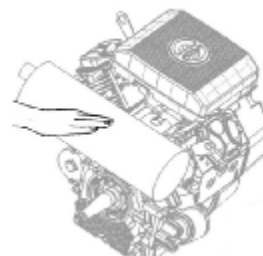

8. If running test is to be done on work site after maintenance, take care to ensure good ventilation, and smoking and flame are prohibited near fuel, grease and other inflammables.



- **Marking position of engine number**
Engine number, model and name are marked on the crankcase. The number is needed for ordering parts or for enquiry.

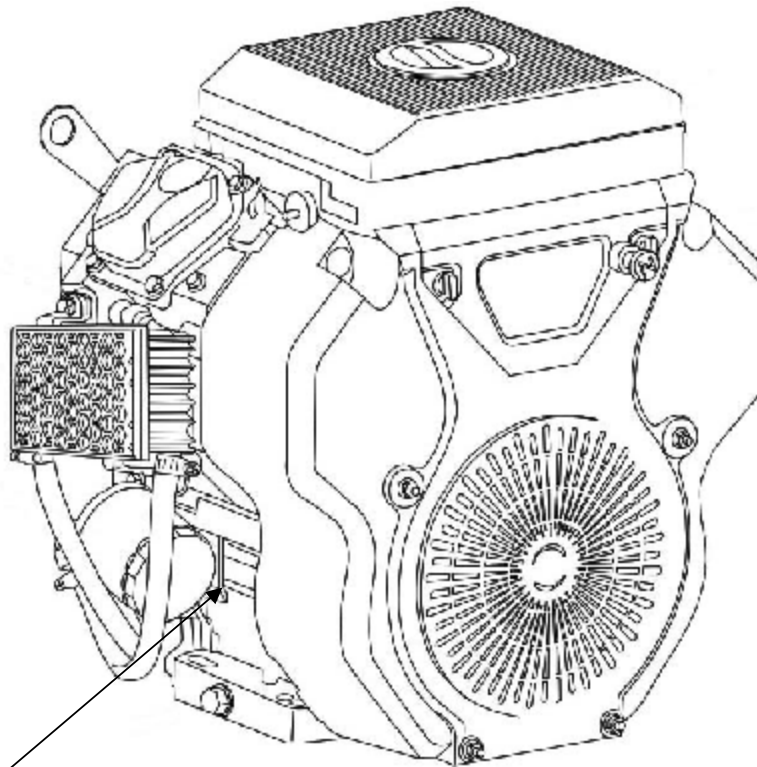

Engine number marking
position

2-2 Maintenance standards

Part	Item	Standard	Operation limit
Gasoline engine	Maximum idling speed	3600-3800rpm	--
	Cylinder pressure	$\cong 1.15\text{Mpa}$ (1400rpm)	--
Cylinder	Cylinder bore	78.0mm	78.165mm
Cylinder head	Warpage	--	0.10mm
Piston	Piston skirt outer diameter	77.985mm	77.845mm
	Piston-cylinder clearance	0.02-0.05mm	0.12mm
	Piston pin hole inner diameter	18.005mm	18.048mm
	Piston pin outer diameter	18.0mm	17.954mm
	Piston pin-piston pin hole clearance	0.005-0.027mm	0.06mm
Piston ring	Piston ring side clearance: First/second ring	0.03-0.07mm	0.15mm
	Oil ring	--	--
	Piston ring closing clearance: First/second ring	0.2-0.4mm	1.0mm
	Oil ring	0.15-0.35mm	1.0mm
Piston ring width: First/second ring	Oil ring	2.0mm	1.87mm
	Oil ring	2.5mm	2.37mm
Connection rod	Small end inner diameter	18.002mm	18.07mm
	Big end inner diameter	40.02mm	40.066mm
	Big end oil clearance	0.029-0.064mm	0.12mm
	Small end side clearance	0.2-0.5mm	1.1mm
Crankshaft	Crankshaft outer diameter	39.98mm	39.92mm
Valve	Valve clearance Inlet	0.15 \pm 0.02mm	--
	Exhaust	0.20 \pm 0.02mm	--
	Valve rod outer diameter Inlet	6.6mm	6.438mm
	Exhaust	6.6mm	6.435mm
	Valve guide inner diameter (Ex./In.)	6.60mm	6.672mm
	Tappet clearance Inlet	0.02-0.044mm	0.1mm
	Exhaust	0.06-0.087mm	0.12mm
Valve seat contact width	0.8mm	2.0mm	
Free length of spring	39mm	37.5mm	
Camshaft	Cam height Inlet	29.69mm	29.44mm
	Exhaust	29.7mm	29.45mm
	Journal outer diameter	16.984mm	16.916mm
Crankcase cover	Camshaft hole diameter	17.0mm	17.048mm

Carburetor	Main jet	0. 90	--
	Float height	14±1.5mm	--
	Number of turns of mixture adjusting screw	2-1/8 圈	--
Spark plug	Clearance	0.7-0.8mm	--
Spark plug cap	Electric resistance	9kΩ	
Ignition coil	Electric resistance	Primary side	1.0-1.2Ω
		Secondary side	5.9-7.1kΩ
	Ignition clearance	0.4-0.6mm	--

2-3 Tightening torque values of fasteners

1) Torque parameters

Item to be tightened	Fastener	Tightening torque		
		(N·m)	Kg·m	lb·ft
Cylinder head bolt	M6×1.0	10±2	1.0±0.1	7.5±1.5
Bracket adjusting nut	M6×1.0	10±2	1.0±0.1	7.5±1.5
Crankcase cover	M8×1.25	28±2	2.8±0.2	21±1.5
Connection rod cap bolt	M7×1.25(special bolt)	18±1	1.8±0.1	13±1
Air filter fixing nut	M6×1.0	8±2	0.8±0.1	6±1.5
Muffler fixing nut	M8×1.25	24±2	2.4±0.2	18±1.5
Engine oil drain plug	M14×1.5	50±3	5±0.1	37.5±2.5
Engine oil alert device	M6×1.0	8±1	0.8±0.1	6±1
Flywheel installing nut	M20×1.5(special nut)	120±5	12±0.2	90±4

2) Standard torque parameters

Fastener	Thread specifications	Torque (N ² m)		
		(N • m)	Kg • m	lb • ft
Bolts, nuts	5mm bolt and nut	4.5-6	0.45-0.6	3.4-4.5
	6mm bolt and nut	8-12	0.8-1.2	6-9
	8mm bolt and nut	18-25	1.8-2.5	13.5-19
	10mm bolt and nut	29-34	2.9-3.4	22-25.5
	12mm bolt and nut	49-59	4.9-5.9	37-45
	4mm screw	1.5-2.6	0.2-0.3	1.2-3.8
	5mm screw	3.5-5	0.35-0.5	2.7-3.8
	6mm screw	7-11	0.7-1.1	5.3-8.3
	5mm flange bolt	3.6-6.9	0.4-0.7	2.7-5.2
	6mm screw	7-11	0.7-1.1	5.3-8.3
	5mm flange bolt	3.6-6.9	0.4-0.7	2.7-5.2
	6mm flange bolt	10-14	1.0-1.4	7.5-10.5
	8mm flange bolt	20-26	2.0-2.6	15-19.5
	10mm flange bolt	35-45	3.5-4.5	27-33.8
	12mm flange bolt	50-60	5.0-6.0	37-45

2-4 Special tools

Tool name	Tool number	Place to use the tool. Remarks
(1) Float height gauge		For checking carburetor fuel level
(2) Valve guide puller 6.6mm		Removing and installing valve guides
(3) 32 × 35mm outer race assembler		For assembling 6202 ball bearings
(4) 42 × 47mm outer race assembler		For assembling 6204 and 6302 ball bearings
(5) 62 × 68mm outer race assembler		For assembling 6206 ball bearings
(6) 72 × 75mm outer race assembler		For assembling 6207 ball bearings
(7) Assembler grip C		The grip of (8) and (9)
(8) 30mm inner race assembler		For assembling 6206 ball bearings
(9) 35mm inner race assembler		For assembling 6207 ball bearings and timing gear
(10) 15mm auxiliary assembler		For assembling 6202 and 6302 ball bearings
(11) 20mm auxiliary assembler		For assembling 6204 ball bearings
(12) 30mm auxiliary assembler		For assembling 6206 ball bearings
(13) 35mm auxiliary assembler		For assembling 6207 ball bearings
(14) Assembler grip A		The grip of (3), (4), (5), (6), (10), (11), (12) and (13)
(21) Grinder grip 6.6mm		For grinding seat surface
(22) Flywheel remover		For removing flywheel
(23) 15mm bearing puller		For removing 6202 ball bearings
(24) Valve guide reamer 6.6mm		Finishing reaming of valve guide inner wall

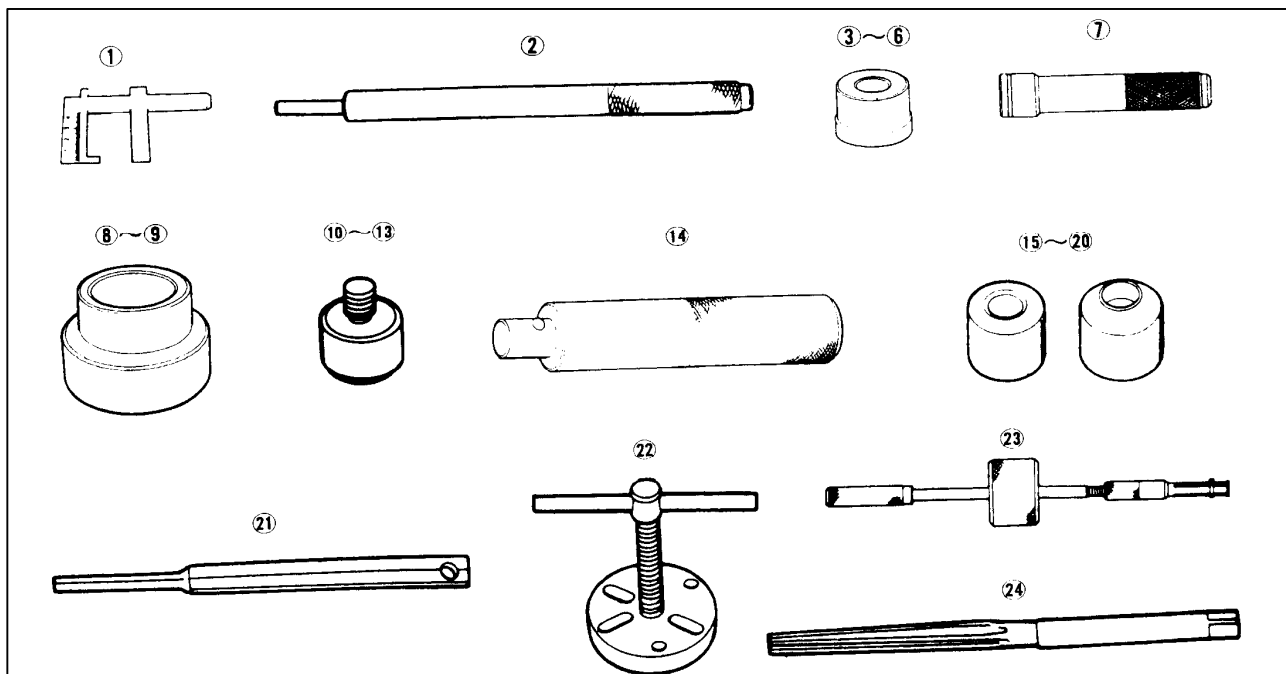

2-5 Diagnosis

1) Major malfunctions and diagnosis

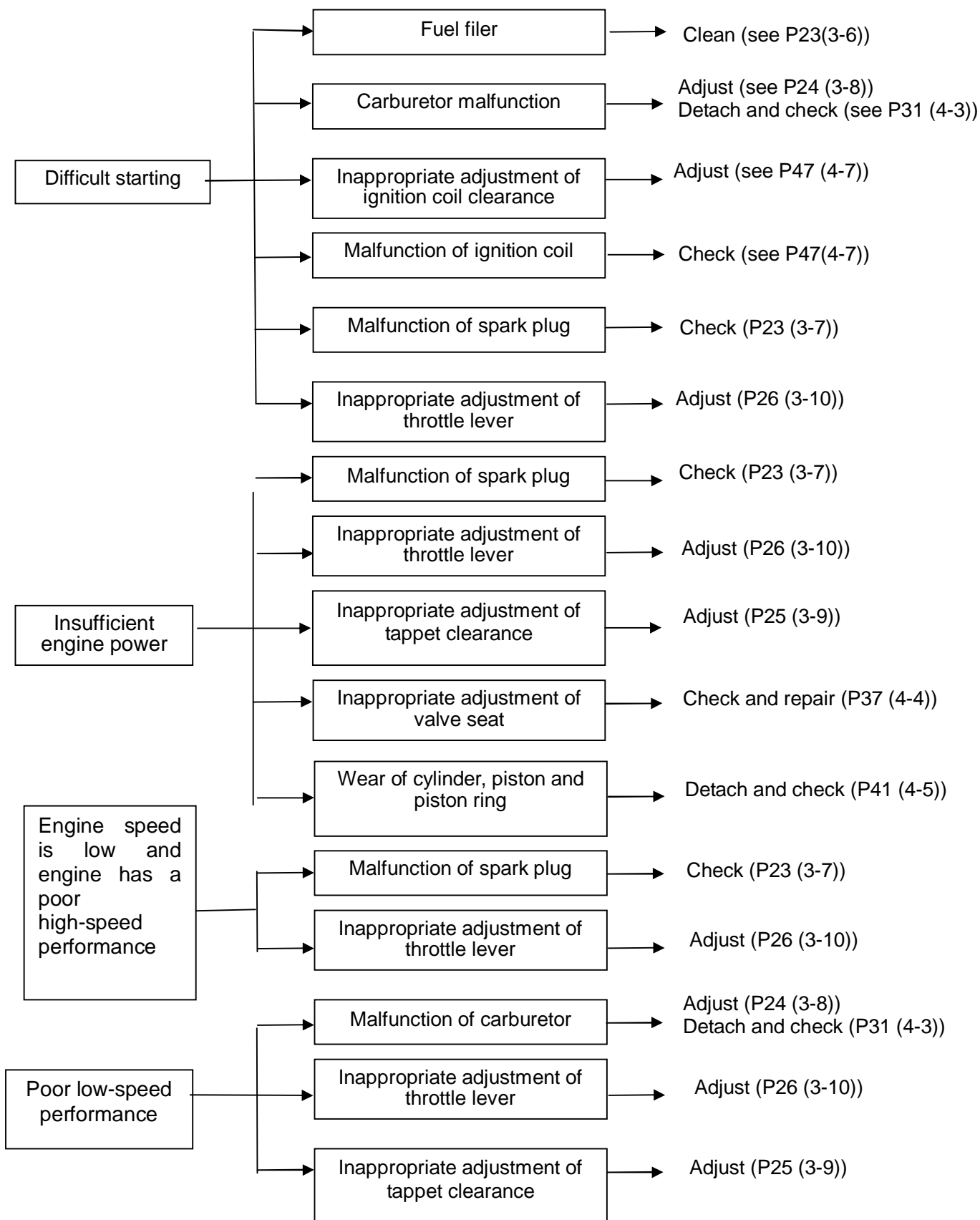

2) Malfunction diagnosis of poor starting performance

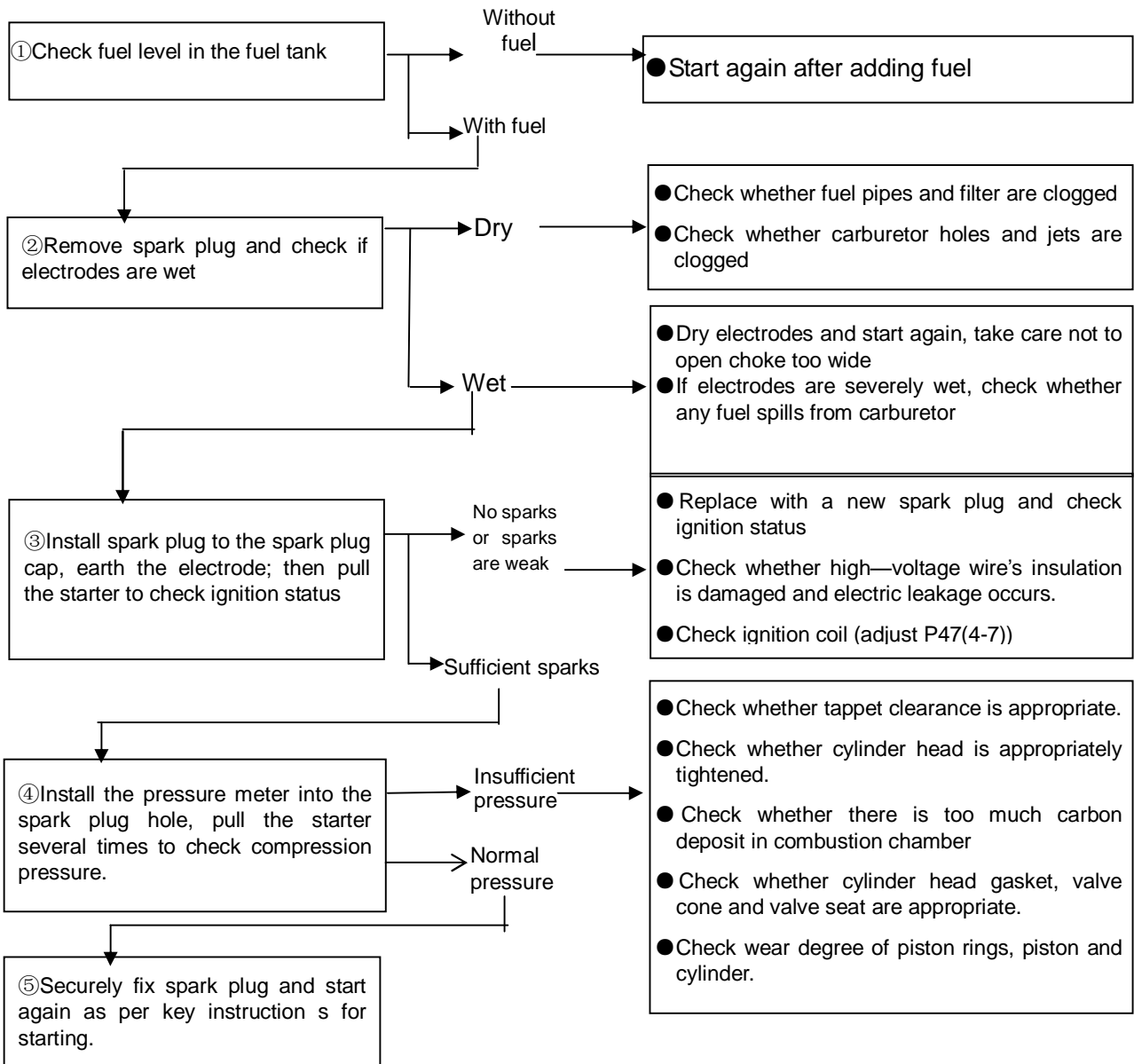

● Check of compression pressure

1) Remove spark plug and spark plug cap.

2) Install pressure meter into spark plug hole, motor to battery, and start several times to measure compression pressure.

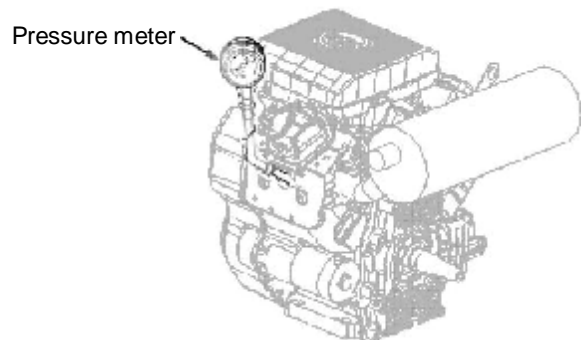

Compression pressure	0.6~0.7Mpa (600rpm)
----------------------	---------------------

3) Diagnosis of malfunction with engine oil alarm device

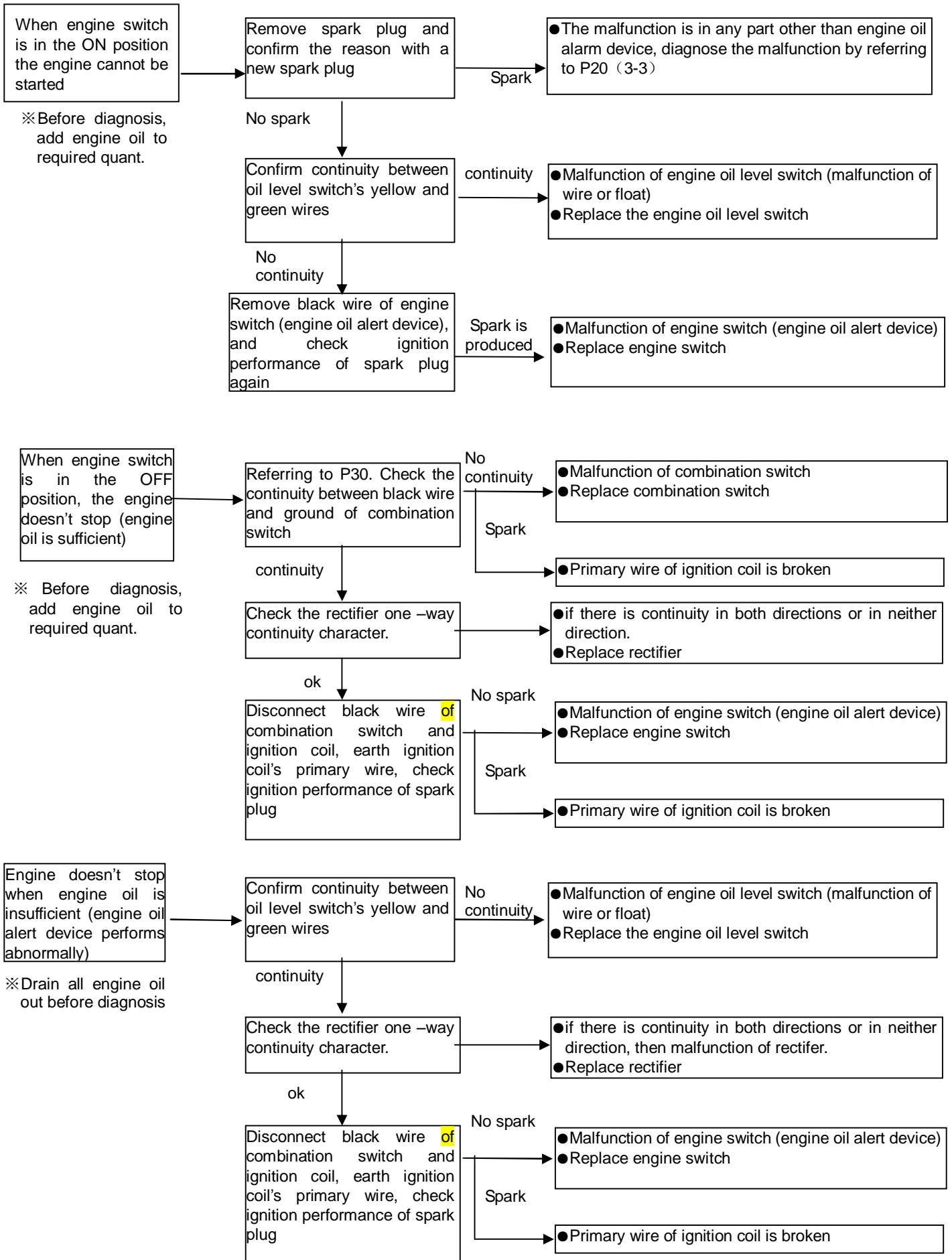

4) Diagnosis of spark plug's inability to produce sparks

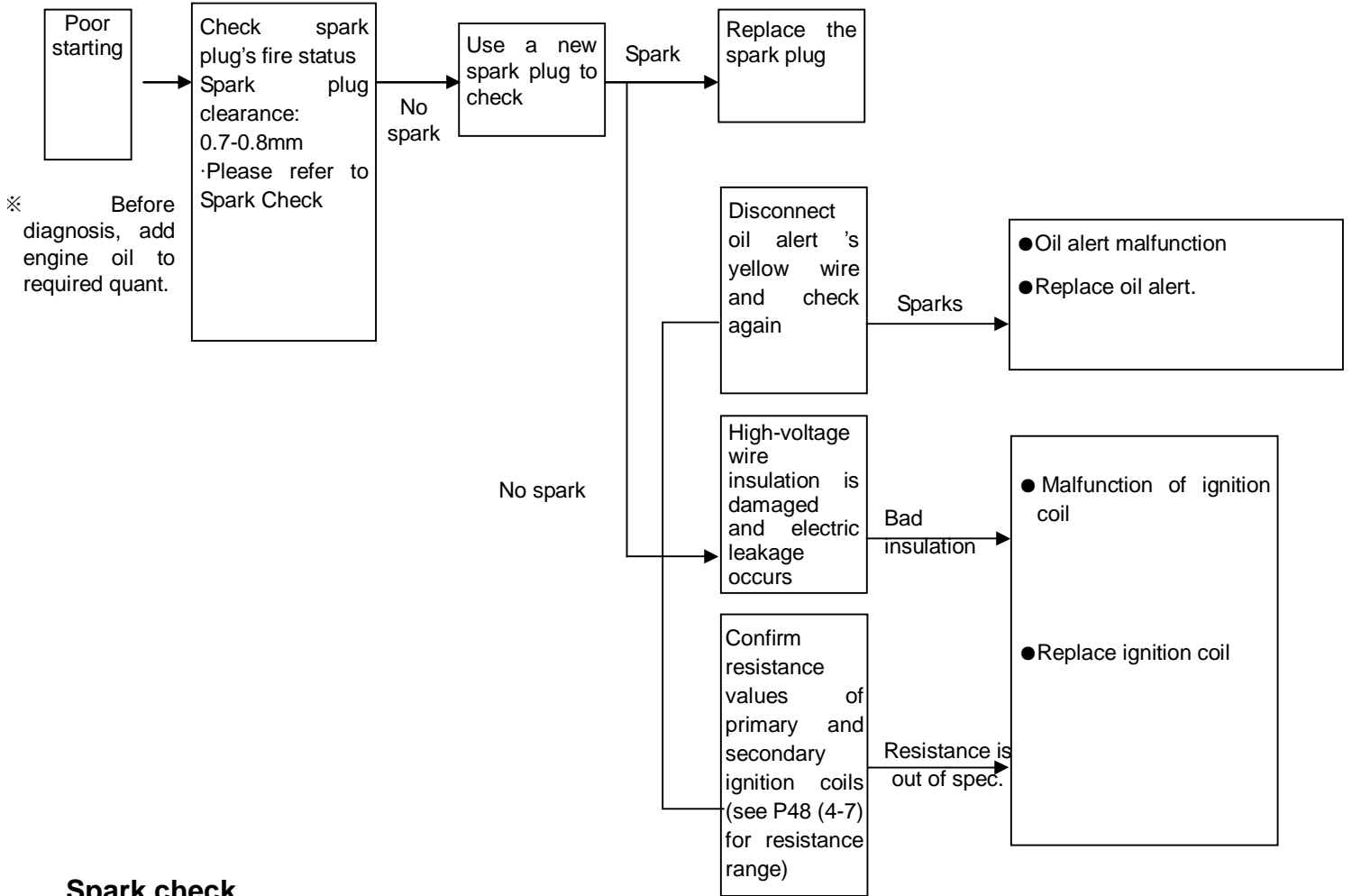

Spark check

Ensure no fuel is spilled out of the gasoline engine and spark plug is not wetted by fuel. In order to prevent fire, never allow any spark to appear near spark plug hole.

When testing spark plug, never hold high-voltage wire of spark plug with wet hands.

- 1) Remove spark plug.
- 2) Install the spark plug to the spark cap and ground the side electrode against the cylinder head cover.
- 3) Turn the engine switch to the “start” position for electric start engine, or turn the engine switch to the “on” position, pull the recoil starter and check to see if sparks jump across the electrodes.

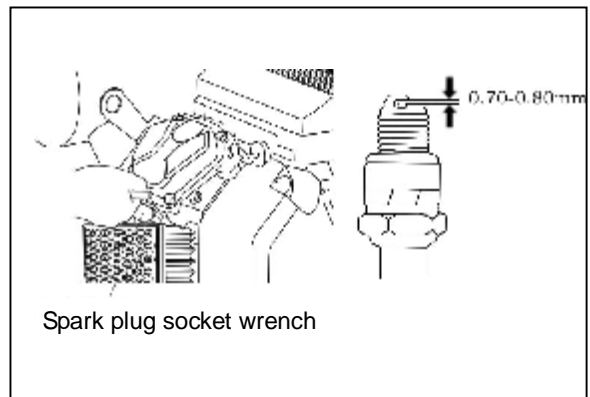

5) Diagnosis of abnormal electric starting

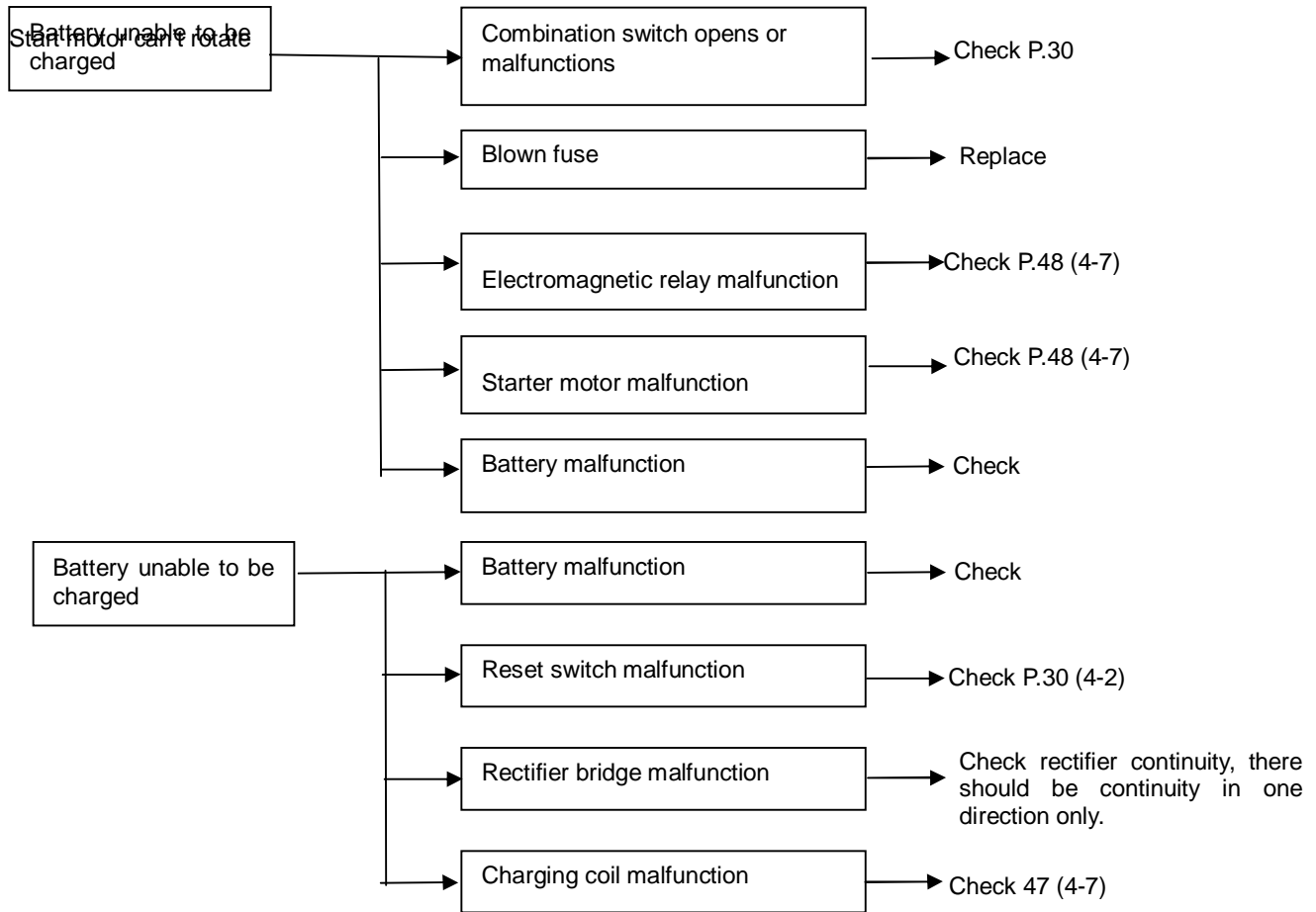

3-1 Maintenance schedule	3-2 Oil change	3-3 Check of oil alarm device
3-4 Maintenance of air filter	3-5 Maintenance of muffler	3-6 Cleaning of fuel filtering system
3-7 Maintenance of spark plug	3-8 Adjustment of carburetor	
3-9 Adjustment of valve clearance	3-10 Adjustment of throttle lever	

3-1 Maintenance schedule

Maintenance schedule		Each use	Firs month or 20 Hrs	Every 3 months or 50 Hrs	Every 6 months or 100 Hrs	Every year or 300 Hrs
Engine oil	Check oil level	●				
	Replace		●	●		
Air filter	Check	●				
	Clean			●(1)		
	Replace					●※
Fuel sediment cup	Clean				●	
Battery electrolyte level	Check	●				
Spark plug	Clean				●	Replace
Valve clearance	Readjust					●(2)
Oil fine filter	Replace		Every 500 Hrs. (2)			
Combustion chamber	Clean		Every 300 Hrs. (2)			
Fuel tank and strainer	Clean		Every two years (2)			
Fuel line	Replace		Every two years (2)			

NOTES:

● Represent Maintain Item.

※Only replace air filter foam or paper filter elment.

(1) Represent maintain more frequently when the engine is used in dusty areas.

(2) These items should be maintained by a dealer authorized by Loncin.

3-2 Oil change

• Engine oil is a major factor affecting gasoline engine's performance and service life. We advise you not to use engine oil containing additive, or to use two-stroke engine oil, because they lack enough lubricating ability and will shorten gasoline engine's service life.

- Stop the engine and put it on level ground before checking engine oil.
- Oil capacity: 1.6L (oil fine filter replaced), 1.5L (oil fine filter unreplaced)

SAE 10W-30 is the recommended general-purpose engine oil for this engine.

If your local ambient temperature is within the range shown in the diagram, engine oils of other viscosity levels can be used.

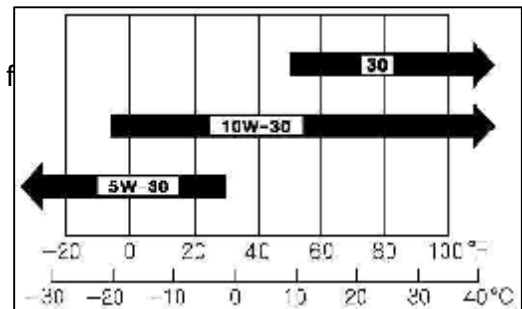

Ambient temperature

Steps of check:

- Remove the oil dipstick and wipe it clean;
- Insert the dipstick into oil filler hole to check oil level,
- If oil dipstick has no oil sticking to it, the oil level is too low. Add recommended engine oil until oil level reaches the upper limit;
- Rescrew in and tighten the oil dipstick.

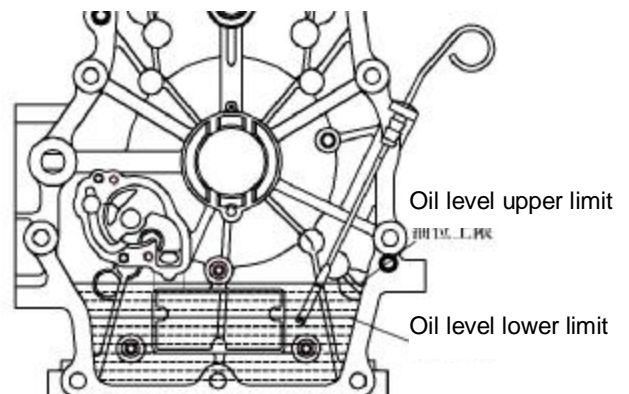

3-3 Check of oil alert device

Oil alert system is specially designed to prevent engine damage caused by an insufficient amount of oil in the crankcase. When the oil level in the crankcase falls to the safe limit, the oil alert system will automatically shut down the engine (the engine switch will remain in the ON position)

If the engine automatically stops and cannot be started, first check oil level, then check if there is any other malfunction.

- 1) When the engine is running, disconnect yellow wire of its switch and ground it via the engine, and confirm the engine is stopped.
- 2) When engine is stopped, engine oil is enough as required, and oil level switch's two wires are not disconnected, if the two wires are conductive to each other, it is normal
- 3) Then, check again with engine oil drained off, if oil level switch's wires are conductive to each other, it is normal.

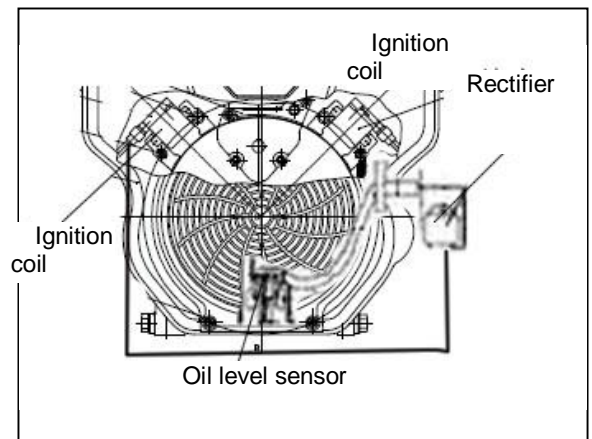

Oil change:

▲ WARNING

• Used engine oil contains harmful substances and may cause skin cancer if repeatedly left in contact with the skin for prolonged periods. Please thoroughly wash your hands with soap and clean water after contacting used engine oil.

NOTICE

• For the sake of environment protection, please treat the used engine oil in an appropriate way. We strongly advise you to store the used engine oil in a sealed container and take it to the local service station or recycling center for used oil reclamation. Remember: never throw it in the trash or pour it on the ground or into the ditch.

3-4 Maintenance of air filter

A dirty air filter will restrict air flow into the carburetor. To prevent carburetor malfunction, maintain the air filter regularly (see page 18, 3-1 for maintenance cycles, and see the drawings below for maintenance method). If engine is operated in a dusty environment, more frequent maintenance is needed.

⚠ WARNING

Using gasoline or inflammable solvent to clean the filter element can cause a fire or explosion. Use only soapy water or nonflammable solvent.

NOTICE

Never start the generator without the air filter, or the gasoline engine will wear more rapidly.

01 Loosen the air filter cover's rotary button to remove air filter cover. Check air filter element to confirm it is intact and clean.

02. If the foam element is dirty, clean it following the method below: Wash the element in a solution of household detergent and warm water, or in a nonflammable (or high flash point) solvent, then rinse it with clean water, and squeeze water out thoroughly, then drip some drops of engine oil and squeeze to evenly distribute them

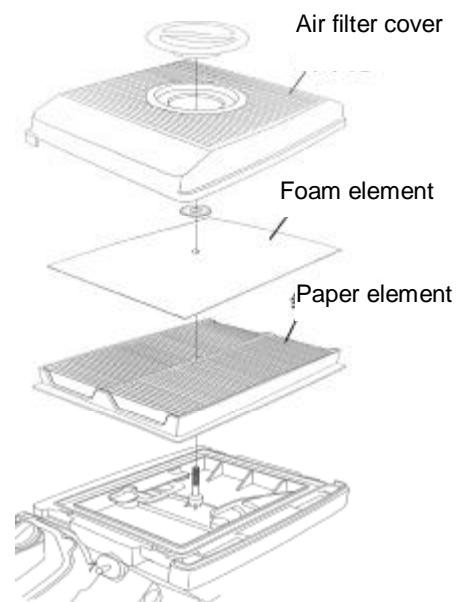

03. Re-install the air filter element and the cover.

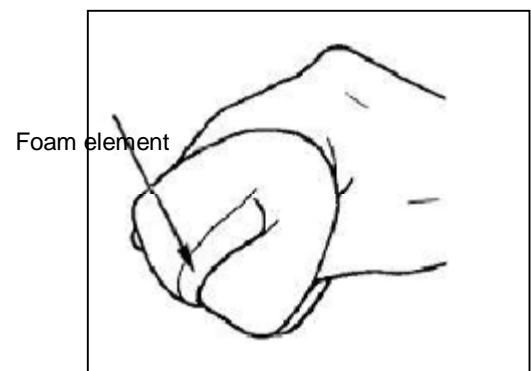

3-5 Maintenance of muffler

Carbon will deposit on muffler after a long period of use, and will severely influences the exhaust system. In order to ensure better performance of the exhaust system, we normally have to remove carbon deposit from the muffler. For removing the carbon deposit, we can gently knock the muffler with a hand hammer, and use compressed air to blow it. If the muffler has water drop deposit, or is severely eroded, which causes higher exhaust noise, it shall be replaced with a new one.

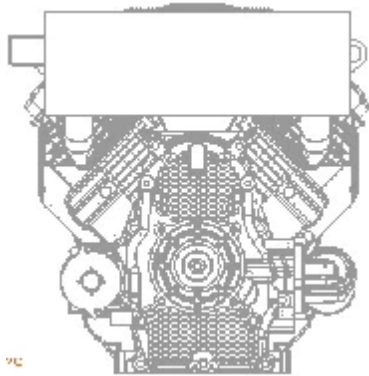

Installing:
First gently knock the muffler with a plastic hammer or another tool to remove carbon in it, then install it

NOTICE

Never use iron wires to clean the muffler, or the sound insulation, or the acoustical absorbing material will be scraped away and muffler's performance will be lowered.

Muffler's seal gasket cannot be used again.

WARNING

- The muffler will heat up, please install the gasoline engine in a place inaccessible to passers-by and children.
- When the gasoline is running, never put any flammable material near the exhaust port.

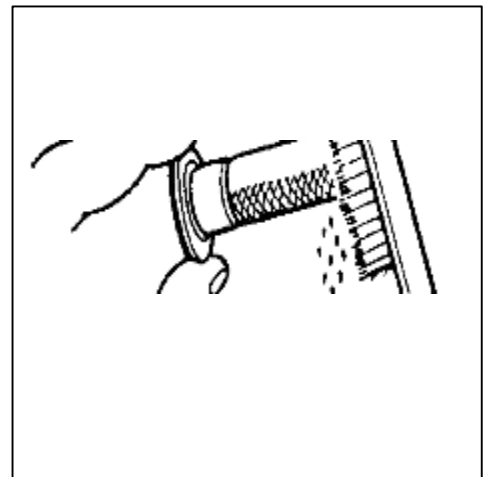

Spark arrester:
First remove carbon deposit with a brush or another tool, then install it.

3-6. Cleaning of fuel filtering system

Smoking and flame are prohibited during cleaning. It should be confirmed that no fuel spills out after tightening. Clean the sediment cup in a nonflammable solvent and air-dry it completely.

3-7 Maintenance of spark plug

Recommended spark plug: F7RTC

- Remove spark plug cap,
- Use the spark plug socket wrench to remove the spark plug.
- Visually check if the spark plug's insulation is damaged, if so, replace it with a new one; if the electrode has carbon deposit, clean it with a wire brush.
- Measure the plug clearance with a feeler gauge. The correct clearance should be: 0.70-0.80mm (0.028-0.031 in). If adjustment is necessary, gently knock it (if the clearance is too big), or use a slotted screwdriver to slightly lever up the electrode (if the clearance is too small).
- Check whether the spark plug washer is in a good condition.
- Reinstall the spark plug and use the spark plug socket wrench to fasten it into the cylinder head, then reinstall spark plug cap.
- In order to prevent thread misalignment when installing spark plug, use hands first to screw (in the direction as shown in the drawing) spark plug into threaded hole in the cylinder head, then use a special socket wrench to tighten it.
- If a new spark plug is installed, make another 1/2 turn after pressing tight the washer.
- If a used spark is reinstalled, make another 1/8-1/4 turn after pressing tight the washer.

Spark plug tightening torque: $28 \pm 2 \text{ N} \cdot \text{m}$

Recommended spark plug: F7RTC or another model of the equivalent grade.

A wrong model of spark plug will lower engine's performance, or even damage the engine.

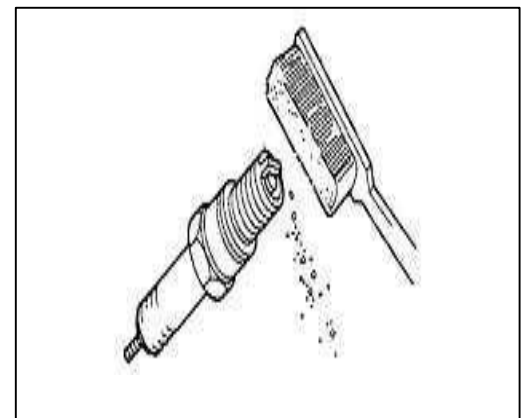
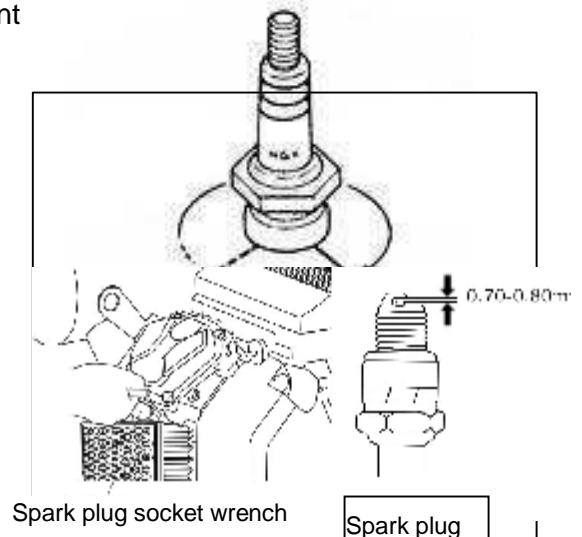

3-8 Adjustment of carburetor (idling speed)

- 1) Start the engine; warm it up for about ten minutes.
- 2) After warming up, let engine run idle, and adjust the auxiliary air adjusting screw clockwise or counter-clockwise, and set it in the position where the engine speed is the highest.
- 3) After adjustment to auxiliary air adjusting screw, turn the throttle stop screw to adjust idling speed.

Prescribed idling speed	1, 500 ± 150 rpm
-------------------------	------------------

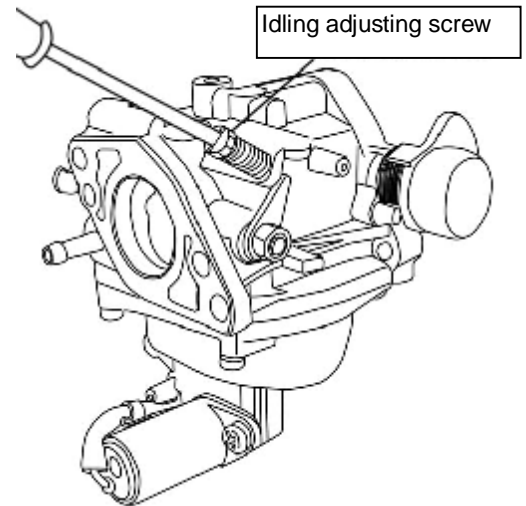

3-9 Adjustment of valve clearance

NOTICE Adjustment to valve rocker clearance should be conducted when the engine is cool.

- 1) Remove cylinder head bolts, cylinder head guard and cylinder head gasket (see P34)
- 2) Remove the fan cover, (see P31).
- 3) Rotate the vane wheel clockwise; when inlet valve and exhaust valve are both closed, rotate vane wheel again, when the valve rockers don't move, the timing position is reached.
- 4) Put the feeler gauge into the clearance between the rocker and valve adjusting cap to measure valve rocker clearance.
- 5) If adjustment is needed, take the following steps to adjust:
 - a. Use a wrench to fix rocker shaft and loosen the stop nut,
 - b. Loosen the rocker shaft and adjust to reach the prescribed tappet clearance,
 - c. Use a wrench to fix rocker shaft, tighten the stop nut,
 - d. After tightening stop nut, re-check tappet clearance.

Valve clearance	Inlet	$0.15 \pm 0.02\text{mm}$
	Exhaust	$0.20 \pm 0.02\text{mm}$

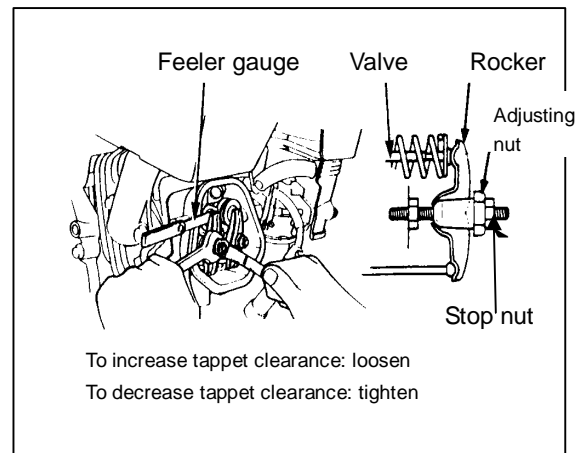

Nut adjustment	Valve clearance
Tighten	Decrease
Loosen	Increase

3-10. Adjustment of throttle

- a) Loosen the nut (M6) to ensure carburetor throttle is fully opened.
- b) At the position where throttle is fully opened, press on the throttle lever bracket and rotate throttle lever clockwise to the limit, then tighten the nut.

Torque: 10N.m

- c) Check if throttle lever bracket and throttle can move freely
- d) Check gasoline engine’s maximum idling speed.
- e) Adjust gasoline engine’s maximum idling speed:
- f) Start the gasoline engine to let warm up to the normal starting temperature,
- g) If gasoline engine’s maximum idling speed doesn’t meet prescribed value, please adjust screw or lever.

Throttle Control Assembly for Generator

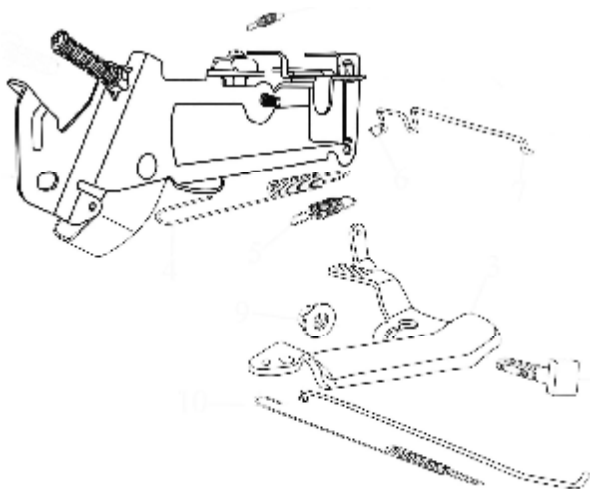

Throttle Control Assembly for other purpose

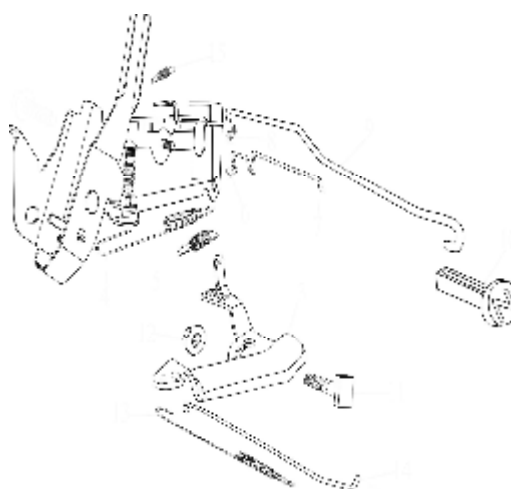

Gasoline engine maximum idling speed	3800rpm
Too fast a speed	Turn adjusting screw counterclockwise or pull the lever
Too slow a speed	Turn adjusting screw clockwise or pull the lever

4-1 Air filter and muffler	4-2 Starter and control box	4-3 Carburetor
4-4 Cylinder head and valves	4-5 Piston, connection rod and crankshaft	
4-6 Crankcase cover and speed governor	4-7 Flywheel, ignition coil and starter motor	

4-1. Air filter and muffler

4-1-1. Dismantling and assembly of air filter

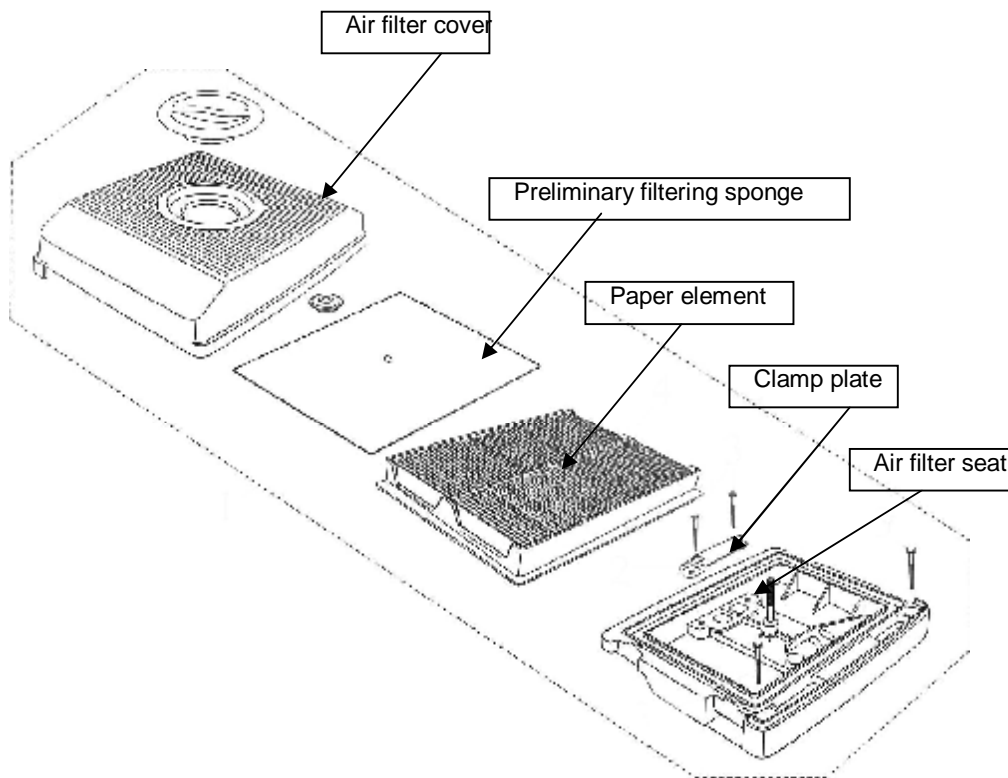

4-1-2. Dismantling and assembly of muffler

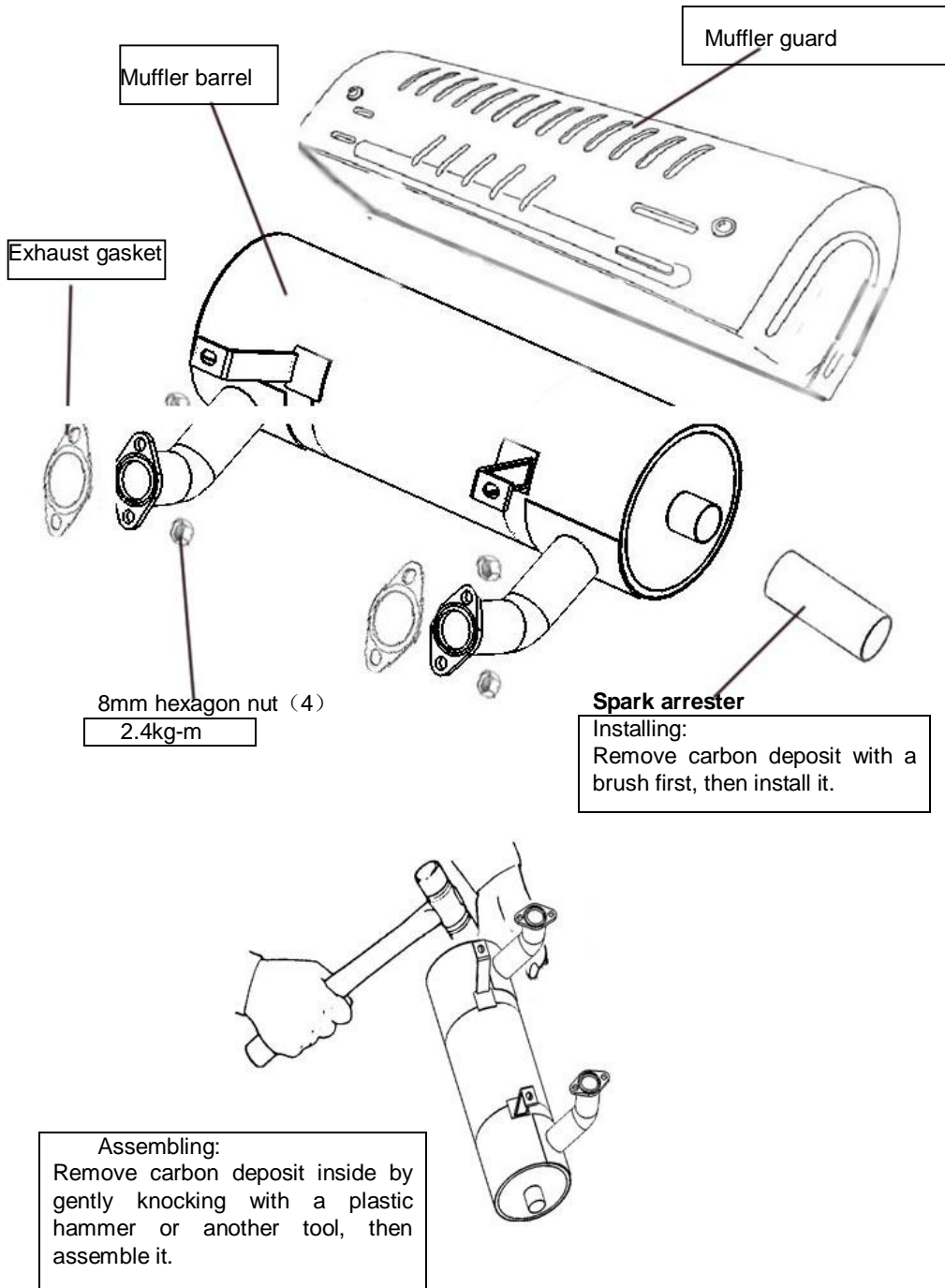

4-2 Starter and control box

a. Dismantling and assembly

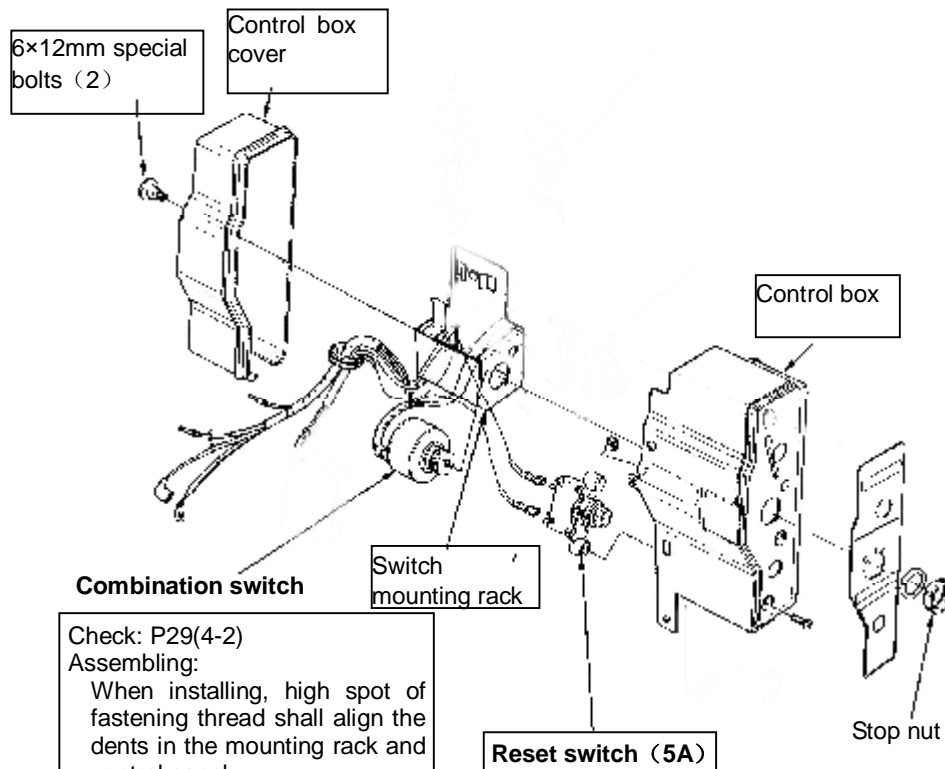

Check: P29(4-2)
 Assembling:
 When installing, high spot of fastening thread shall align the dents in the mounting rack and control panel.

Combination switch

突起
 High spot

Check: P29(4-2)
 Assembling:
 Take care not to inverse the left and right sides.

b. Check

● **Combination switch**

Check connectivity between wires with the switch in different positions.

Wire color position	Black	Ground	Black/ White	White	Black/ White (plug)
OFF	TM _____ TM				
ON				TM _____ TM	
START			TM _____ TM		TM _____ TM

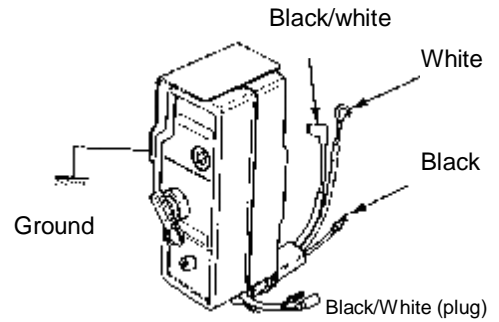

Check has to be conducted when fuse is connected.

● **Reset switch**

Check conduction between two terminals with the switch in the ON position.

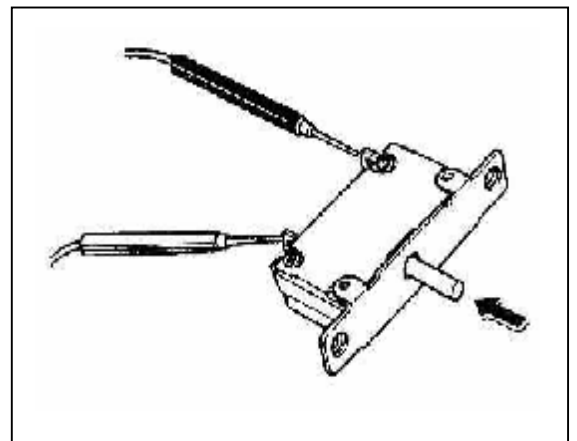

4-3. Carburetor

a. Removal and disassembling

NOTICE

Smoking prohibited

- 1). Disassemble air filter (see P27)
- 2). Remove fan cover

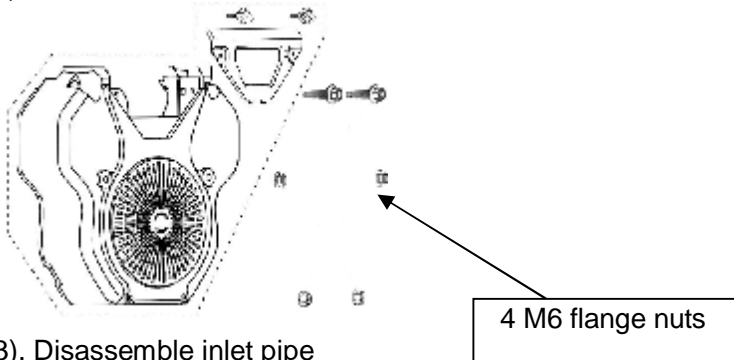

- 3). Disassemble inlet pipe
- 4). Remove carburetor

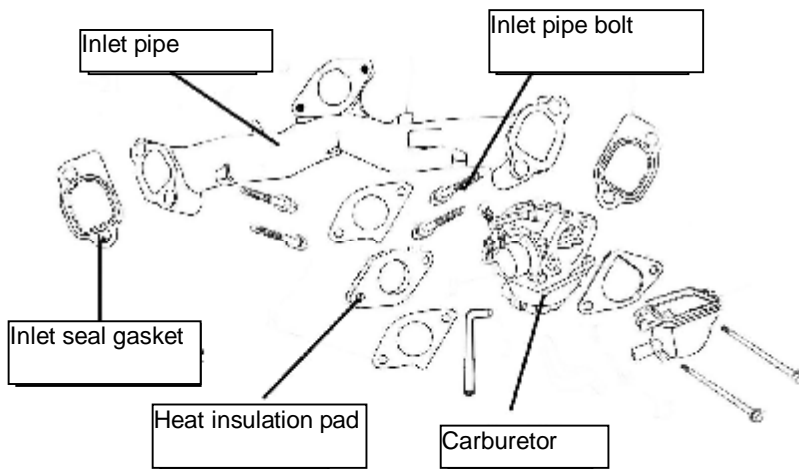

b. Disassembling and assembling

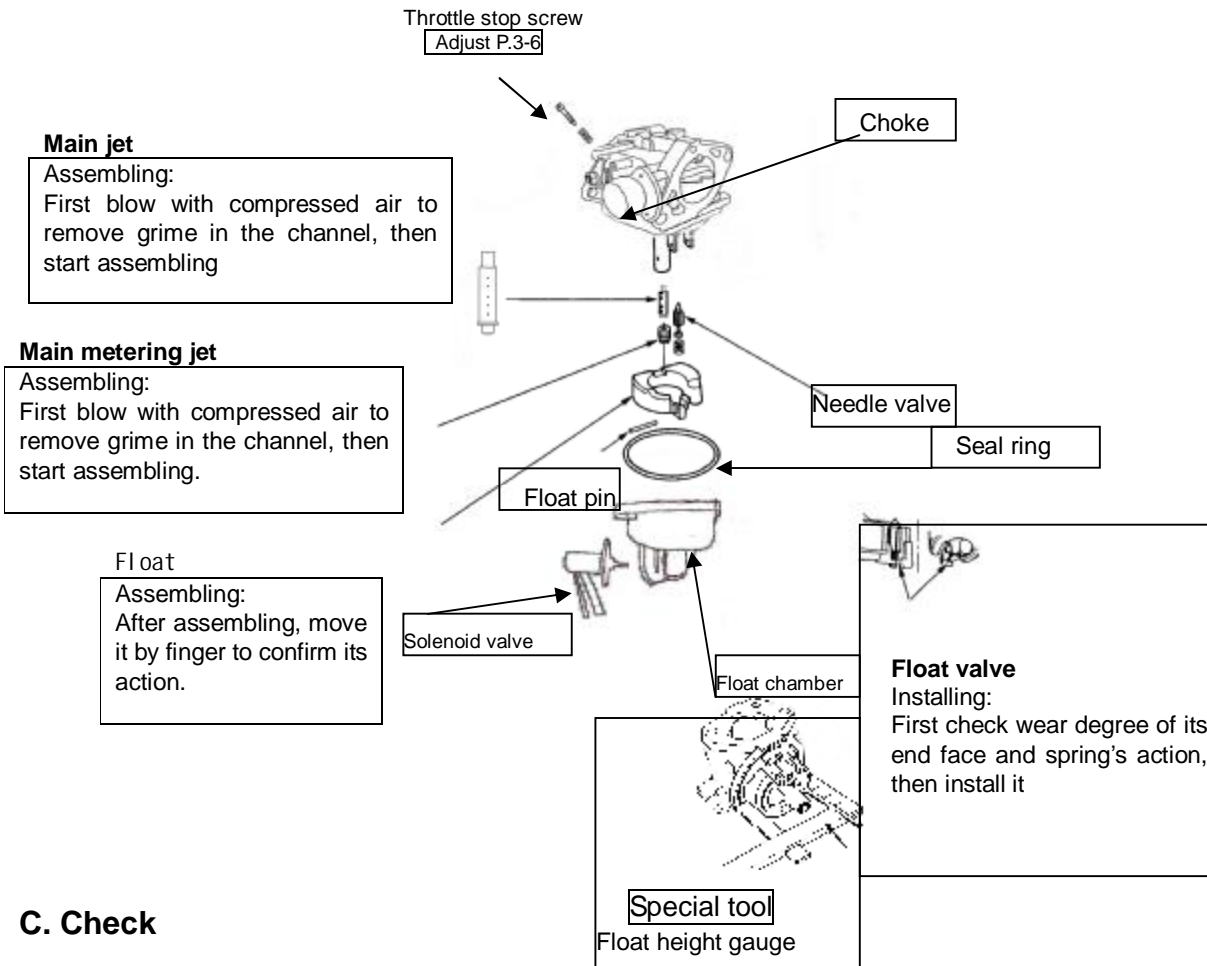

C. Check

● Float height

Put the carburetor as shown in the drawing,

Use fingers to push float in.

At the place where foot of float valve starts action,

Measure the distance between float and housing (float height).

Prescribed float height	14±1.5 mm
-------------------------	-----------

When float height is different from the prescribed value, replace the float

4-4. Cylinder head and valves

4-4-1. Disassembling and assembling of cylinder head

1) Dismantling/installing

- ① Remove cylinder head cover and air guide sleeve
- ② Remove fan cover: see P31
- ③ Remove inlet pipe: see P31

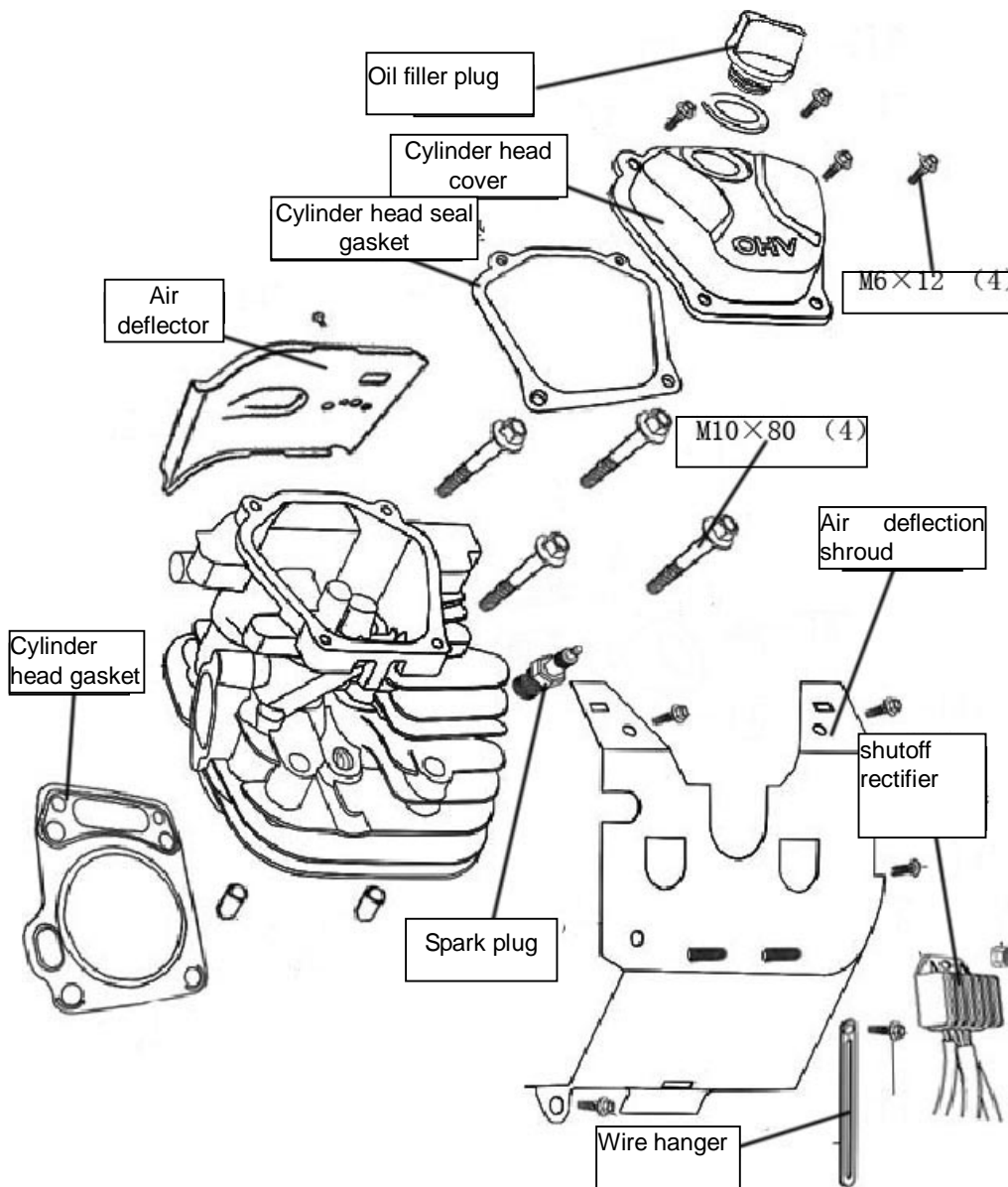

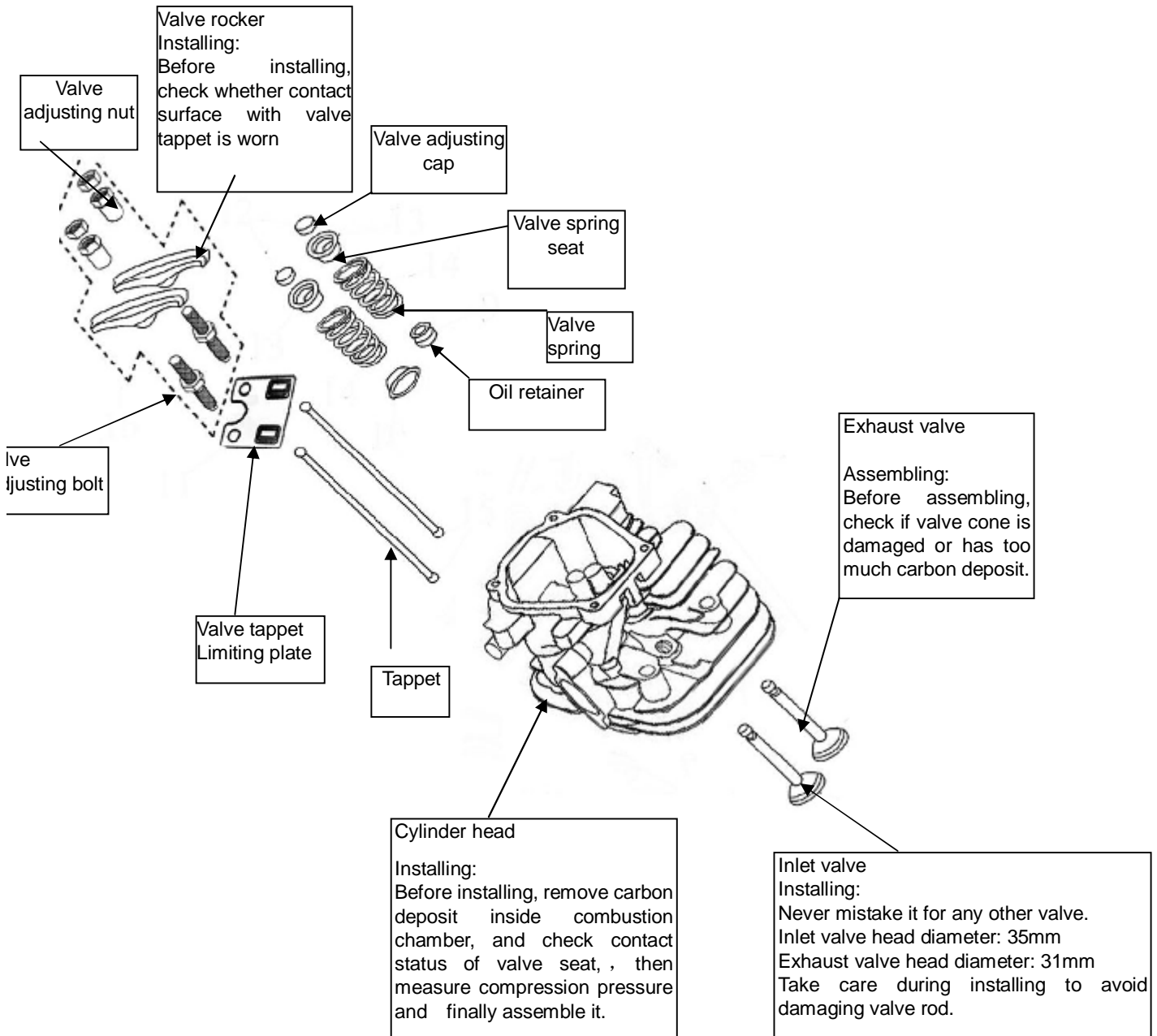

Remove Valve spring seat:

Horizontally move valve rod's front end in the central hole of spring seat, and remove it.

If cylinder head is already installed onto the cylinder, spring seat rings might fall into the crankcase; take care to avoid such an accident.

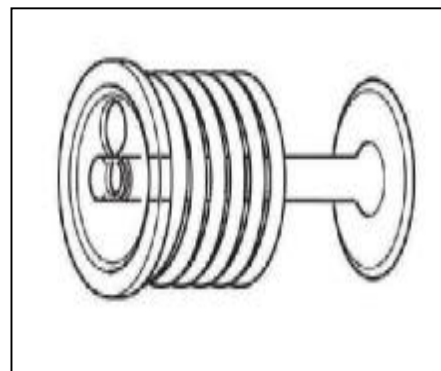

2) Check/maintenance/repair:

① Valve rod outer diameter

Use a micrometer to measure outer diameter of valve rod, if it is smaller than the standard vale or exceeds repair limit, or there is visually observed ablation on or cracks in the valve face, the valve should be replaced with a new one.

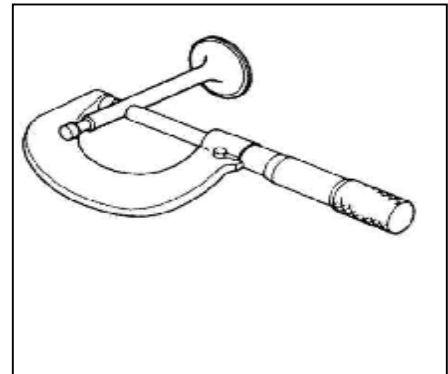

Standard		Repair limit	
6.6mm(inlet)	6.6mm (exhaust)	6.438(inlet)	6.435(exhaust)

② Free length of valve spring

Measure free length of valve spring.

If it is smaller than the standard vale or exceeds repair limit, replace it with a new one

Standard	Repair limit
39mm	37.5mm

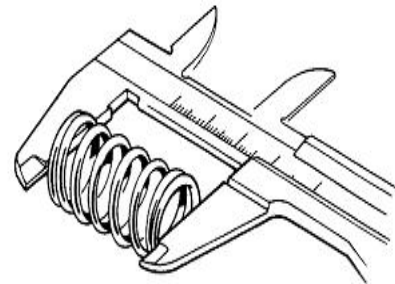

③ Valve guide

Check:

a) Check whether valve guide's inside surface is complete and smooth without scratches, and whether fit between valve guide and cylinder head is firm.

b) Before measuring inside diameter of valve guide, use a valve guide reamer to remove carbon deposit in the valve guide

If valve guide's inside diameter is smaller than standard valve or exceeds repair limit, replace it.

Standard	Repair limit
6.6mm	6.672mm

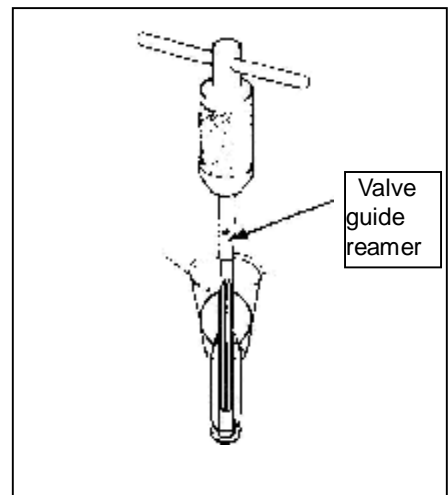

Replace:

a) Put the new valve guide in a refrigerator's freezing compartment to freeze it for about one hour.

b) Use a valve guide puller to remove valve guide from the side of the combustion chamber

NOTICE

When removing valve guide, take care not to damage cylinder head

c) Install the new valve guide from valve spring side of cylinder head.

Exhaust valve side: knock exhaust valve guide until the retainer ring is in full contact with cylinder head (see drawing)

Inlet valve side: knock inlet valve guide until it reaches the prescribed height (measured from top of valve guide to surface of cylinder head (as shown in the drawing))

d) After installing, check whether valve guide is damaged, if so, the valve guide must be replaced.

Reamer:

Precision reaming on the valve using the reamer to must be conducted at the room temperature to ensure a good effect.

a) Apply a thin film of cutting oil on valve reamer and valve guide. Turn the reamer clockwise to let it fully go into valve guide.

Continue turning the reamer clockwise to let it go out of valve guide.

Tool: valve guide reamer

b) Completely remove grim and debris on cylinder head.

c) Check whether valve guide hole is in the center of valve guide and is straight and unobstructed. Insert the valve in it to check

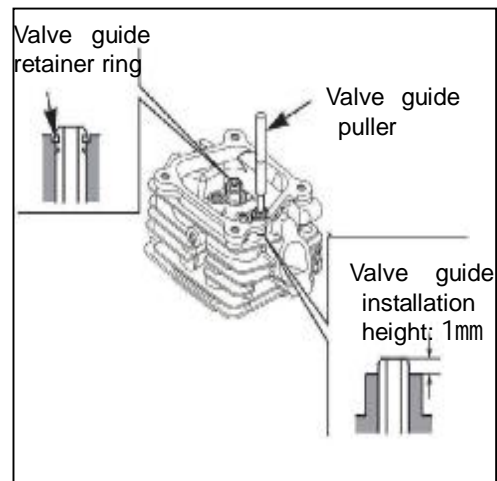
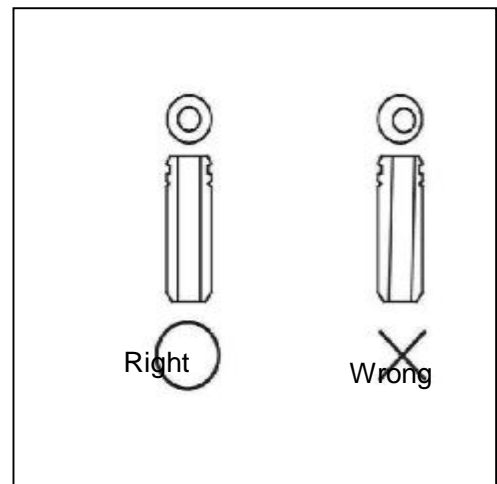
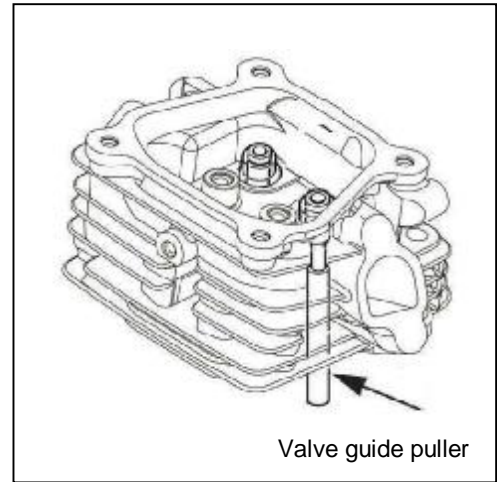

whether it can act freely, if not, the valve guide might have been bent during assembling. If the valve guide is really bent or damaged, replace it with a new one.

d) Check clearance between valve rod and guide.

e) Clearance between valve rod and valve guide: the result of valve guide inner diameter minus valve rod outer diameter is the clearance between valve rod and valve guide.

f) If the clearance between valve rod and valve guide exceeds repair limit, check to determine whether replacing the guide with a new one can restore the clearance back within repair limit, if it can, replace valve guide and ream the valve guide. When conducting the replacement, the valve seat should be shaved.

④ Valve seat:

a) Completely remove the carbon deposit in the combustion chamber and valve seats, apply a thin layer of red inkpad, or another kind of adhesive but easily removable coating on the valve surface.

b) Insert the valve and forcibly press it several times, but take care to ensure valve doesn't rotate in the valve seat

If valve seat is caught by the coating, it means valve and valve seat are in close contact with each other, if valve seat is not caught by the coating, it means the uncolored part of the valve doesn't contact the valve seat, in other words, valve and valve seat are not concentric.

c) User a 45° \u30740X hand valve grinder to grind valve seat, so that a smooth valve seat concentric with the valve can be realized. Turn the grinder clockwise, and counterclockwise turning of it is prohibited.

Tool: hand valve grinder

c) Use a 32° -45° \u30340X hand valve grinder to reduce size of valve seat and adjust its concentricity, so as to let it contact middle part of valve cone.

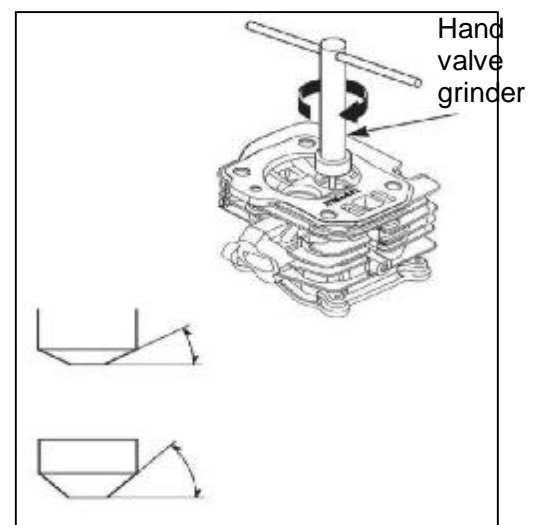
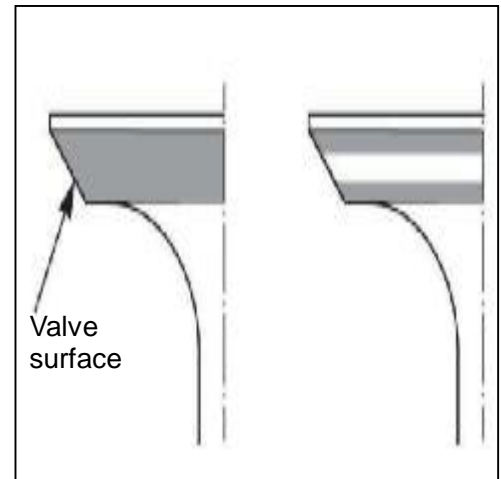

Use a 32° \u30740X hand valve grinder to grind the upper half of valve seat cone (if contact position is too high)

Use a 45° \u30740X hand valve grinder to grind lower half of valve cone (if contact position is too low)

Ensure the valve seat's contact width after grinding is within the prescribed range.

Standard	Repair limit
0.8mm	2.0mm

e) Use a 45°\u30740X hand valve grinder to slightly grind, so as to remove burrs on the valve seat's rim.

f) After repairing valve seat, check width of valve seat, apply coloring agent on valve cone, insert valve and press it forcibly several times, but take care to ensure valve doesn't rotate in the valve seat. If the valve seat's cone is evenly caught by coloring agent as shown in the drawing, it means the cones of valve and valve seat are in good contact.

g) Apply grinding agent on the valve seat cone and turn the hand valve grinder to grind valve seat.

h) Check valve clearance after assembling.

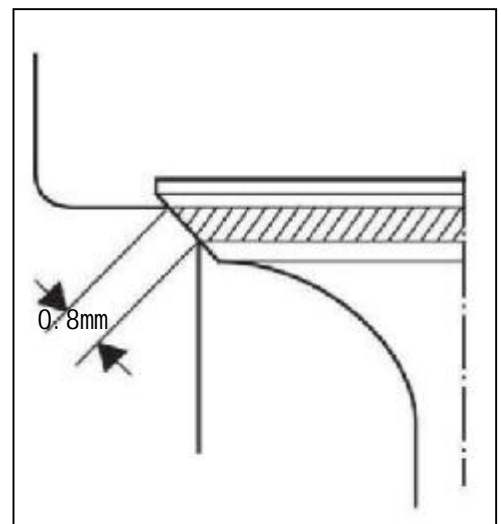
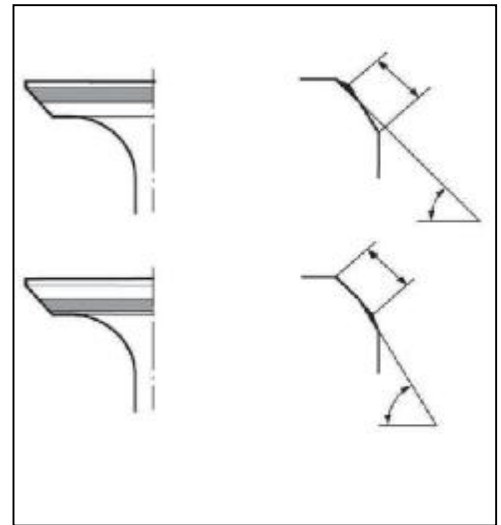

4-5. Piston, connection rod, and crankshaft

1. Installing the piston

a) Piston

When installing the piston, take care to ensure the mark of the manufacturer faces upward, and take care not to confuse first piston ring with second piston ring (first piston ring is coated with chrome)
 After installing, confirm piston rings can act freely.
 Let gap of each piston ring avoid the direction of piston pin, and forms a 120° angle.

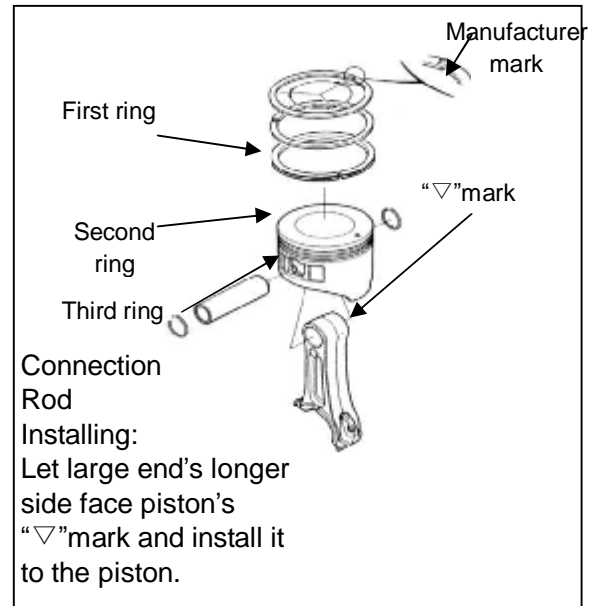

b) Piston pin locking ring

Put front end of locking ring against piston groove, use a pair of nipper pliers to hold its other end, put it into the groove during while rotating it. Take care to let gap of the locking ring avoid piston bottom's recessing part

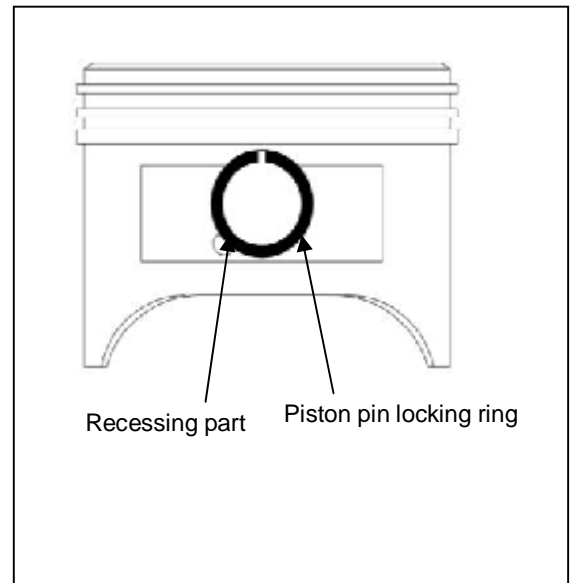

c) Connection rod cap

When installing, connection rod's edge shall be aligned with the connection rod cap's edge

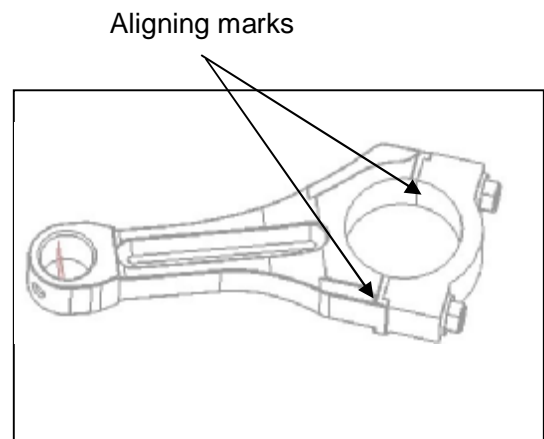

2. Inspection of piston

Check contact between piston and cylinder, defects in rings and grooves, ablation on the top, cracks, etc. if the damage is severe (such as a crack), the piston shall be replaced.

Removing carbon deposit

Carbon deposit is mainly on the top of the piston and rim of the cylinder's upper half. Before inspection, carbon deposit shall be removed. First, use kerosene to drench the positions with carbon deposit, then use a blunt scraper or a metal brush to remove carbon deposit.

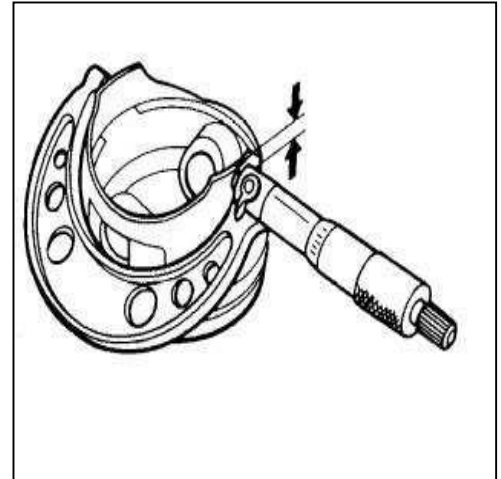

a) Outer diameter of piston skirt

Use an outside micrometer to measure outer diameter of piston skirt, if it exceeds the usable limit, replace it with a new one.

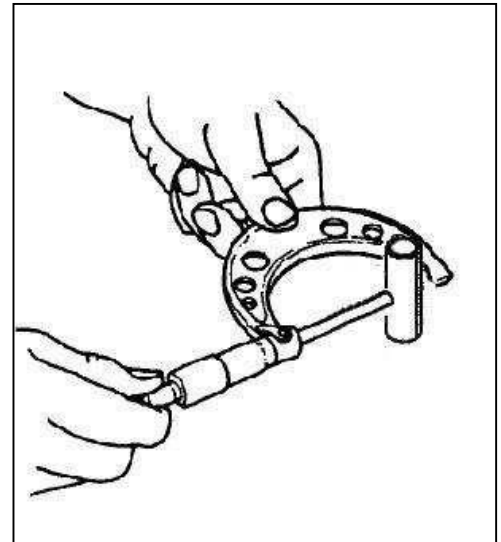

Standard	Repair limit
77.985mm	77.845 mm

b) Clearance between piston pin hole and piston pin

Use an inside micrometer and an outside micrometer to respectively measure inner diameter of piston pin hole and outer diameter of piston pin. Then calculate the clearance according to measuring results. If the clearance exceeds usable limit, the piston or piston pin should be replaced based on their wearing status.

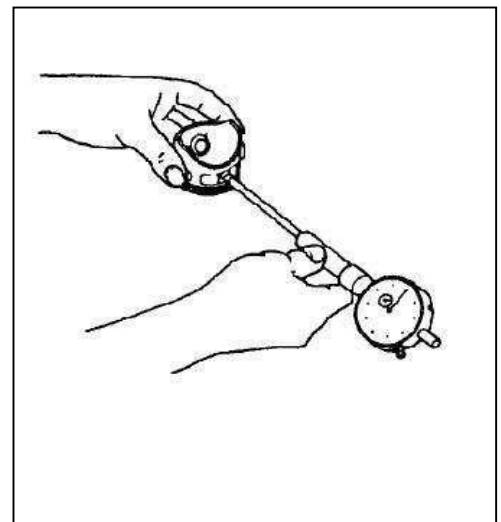

Standard	Repair limit
0.002-0.014mm	0.06mm

c) Piston-cylinder clearance

The difference between cylinder’s maximum diameter and piston skirt’s diameter is the piston-cylinder clearance.

NOTICE

This clearance must be measured before and after repair.

When checking, put the piston upside down in the cylinder, and put a feeler gauge of appropriate thickness between piston skirt’s pressure-bearing surface and cylinder wall, then pull out the feeler gauge, if a resistance is felt but feeler gauge can still be easily pulled out, it means the feeler gauge’s thickness is equal to the piston-cylinder clearance.

Standard	Repair limit
0.02-0.05mm	0.12mm

d) Piston ring side clearance

When checking, put each ring into corresponding piston ring groove, and each piston ring should be able to rotate easily without looseness or unsmoothness.

Then put the feeler gauge between upper sides of the ring and groove, and between the bottom sides of ring and groove to measure piston ring side clearances.

Standard	Repair limit
0.03-0.07mm	0.15mm

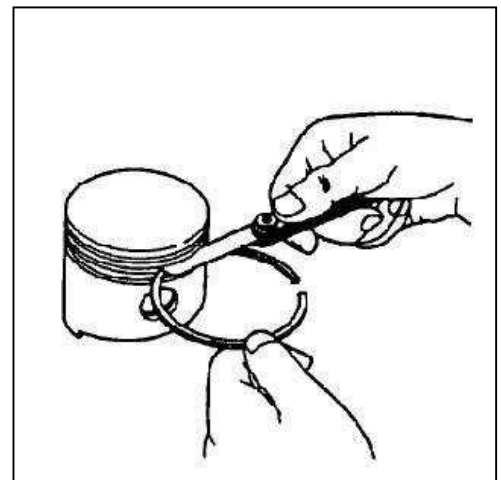

e) Piston ring gap clearance

Put the piston ring into the cylinder, use piston crown to push the ring to the operating position; then use the feeler gauge to measure piston ring gap clearance, which should be neither too big nor too small; if it is too big, cylinder’s sealing performance will be poor; if it is too small, the piston rings expanded by heat in the cylinder would be caught, causing the rings to be broken and even cylinder scoring. If the ring gap is too small, use a fine flat file to repair the gap, and put the ring into cylinder from time to time before the filing is over, so as to check if the gap is appropriate, until the gap is filed to an appropriate size.

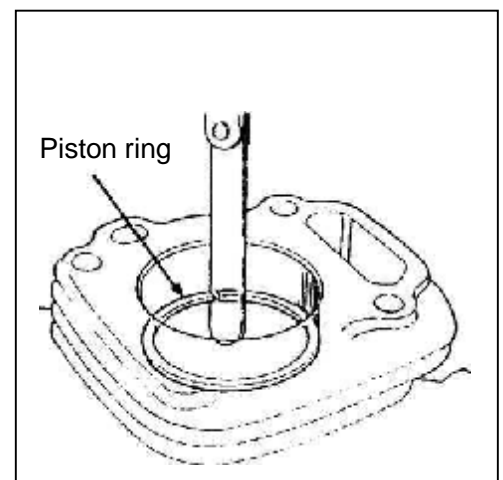

	Standard	Repair limit
First ring/second ring	0.2-0.4mm	1.0mm
Oil ring	0.15-0.35mmmm	1.0mm

3 Inspection of connection rod

If the connection rod is bent, distorted, or its big end’s bearing bush and small end axle bush’s outer race loosen, or one of its ends has cracks, the connection rod shall be discarded and replaced with a new one.

a) Inspection of small end’s inner diameter

If it is smaller than the standard value, or exceeds the repair limit, the connection rod shall be replaced.

Standard	Repair limit
18.006mm	18.07mm

b) Inspection of big end’s inner diameter

If it is smaller than the standard value, or exceeds the repair limit, the connection rod shall be replaced.

Standard	Repair limit
40.02mm	40.066mm

4. Inspection and installation of crankshaft

1) Before installing the crankshaft, crankshaft journal outer diameter should be inspected, if it is smaller than standard value or exceeds repair limit, replace the crankshaft.

Standard	Repair limit
39.966mm	39.906mm

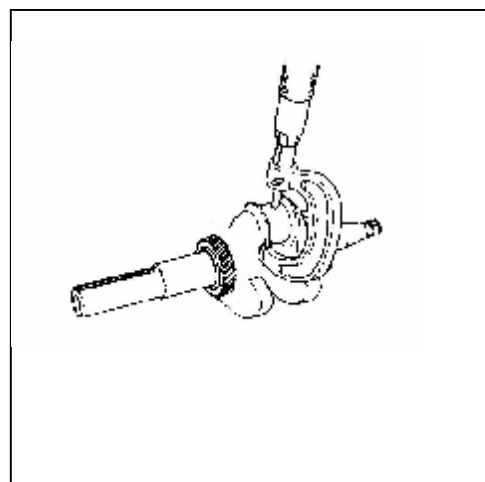
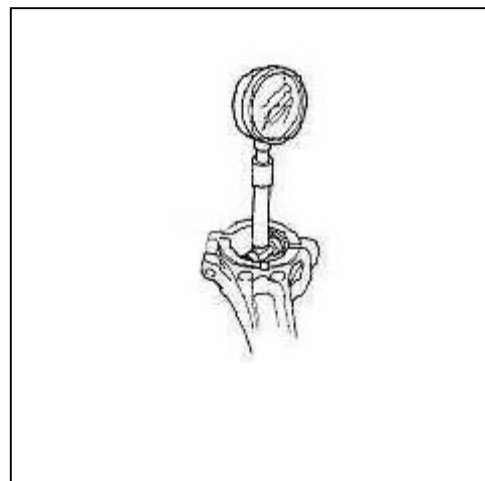
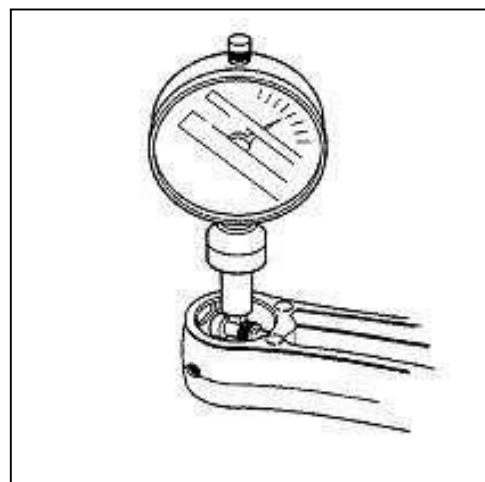

2) Installing the crankshaft

- a) When installing crankshaft, the output end should be upward; take care not to damage oil seal. Install the crankshaft into the crankshaft hole in the crankcase.
- b) Install the governor arm into the crankcase's governor hole, take care to ensure cleanness of the surface.
- c) Install connection rod and piston into crankcase; before installing them, apply lubricant oil evenly on the inside wall of cylinder sleeve; install the piston **with the arrow on its top pointing to the tappets side**. Use connection rod cover to hold crankshaft into the connection rod's big end hole, then tighten the two connection rod bolts.
- d) After installing the crankshaft, manually rotate it to confirm it can rotate easily, and the piston and connection rod can both move downward and upward easily.
- e) When installing camshaft, you have to check whether the spring is fatigued, and confirm the decompressor weight can work easily, then align the timing marks of crankshaft and camshaft assembly, and install the camshaft into crankcase's camshaft hole.
- f) Attach the crankcase cover equipped with oil seal to the crankcase body. When fastening, follow the "N+1" fastening method (first pretighten the first bolt, and firmly tighten it at last).

5. Inspection of camshaft

Camshaft is the gasoline engine valve actuating mechanism's main engine driving piece that can ensure Inlet and exhaust valves open and close following a certain regular way. The structural features of the camshaft is that it has the cams and supporting journals to guarantee its ability to control gas inlet and exhaust, when the cams are working, they are each under a cyclic impact load, the work surface of each cam will rub severely with the tappet and wear or scratch is very likely to occur, so each cam is required to be wear-resistant and has good lubricity.

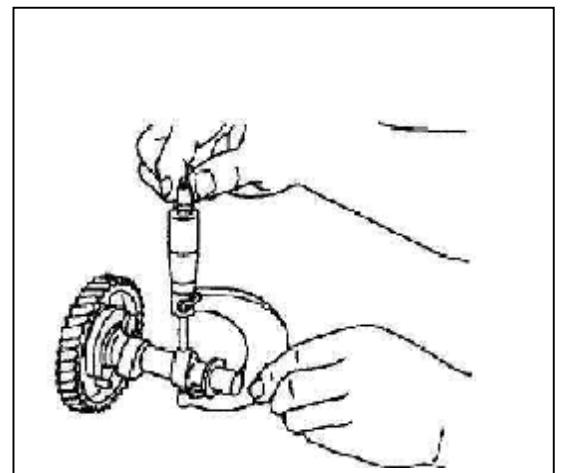
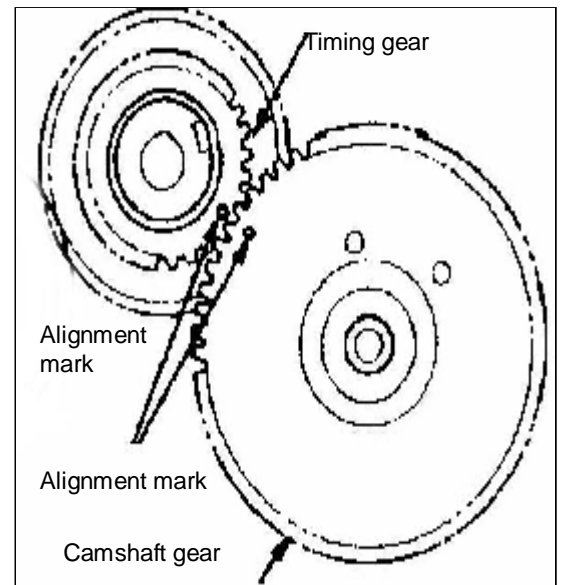

Visually check cam surface and cam height to confirm whether it is damaged, and whether camshaft and bearings are loose or worn, if so, the whole camshaft assembly shall be replaced.

Check height and size of each cam, if the height is smaller than the usable limit, the camshaft shall be replaced.

	Standard	Repair limit
Camshaft ht.(inlet)	29.69mm	29.44mm
Camshaft ht.(exhaust)	29.7mm	29.45mm

Check outer diameter of camshaft journal, if it is smaller than usable limit, replace the camshaft.

Standard	Repair limit
16.984mm	16.916mm

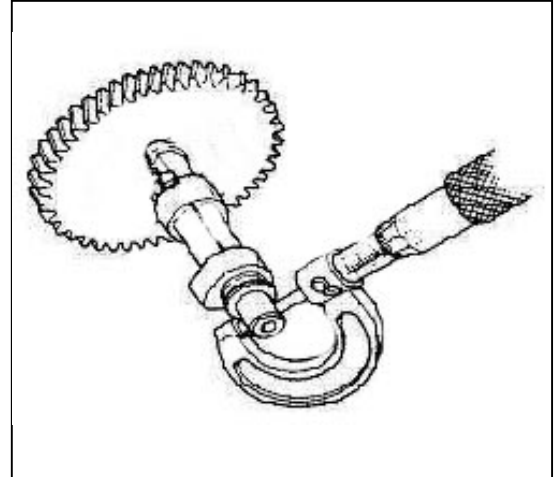

Analysis of reasons for camshaft wear and its influence on the whole engine's performance:

Abnormal wear of camshaft is primarily caused by poor lubrication due to low viscosity of engine oil, high content of impurities in engine oil, low circulation rate of engine oil, etc., which will disable the oil to form a complete film over the surface of camshaft, and hence the severe wear of cam surface when the camshaft is under high-speed dry friction.

The secondary reason is the camshafts' installation accuracy, when fit clearance between camshaft journal and camshaft seat or bearing is out of tolerance, the camshaft's running accuracy will be lowered, and abnormal wear will be caused by the deviation of contact with the engaging part.

Timing gear

Check back lash of timing gears, and make sure the alignment marks of the two pairs of gears are aligned.

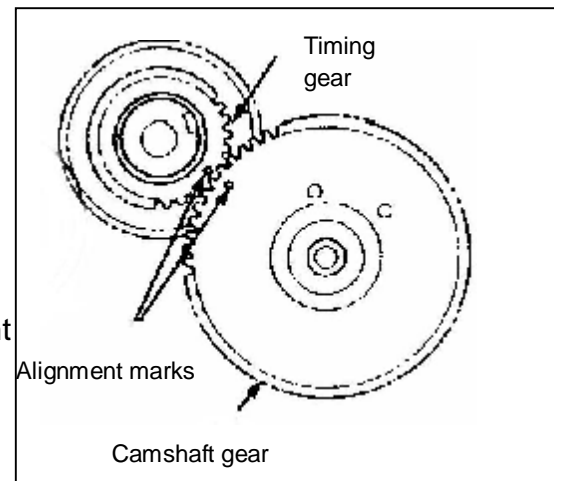

Damage to timing gears is mainly wear to their teeth, flaking of tooth surface or roughened tooth surface, gear runout, tooth breakage, etc. When gear teeth are worn, the gear back lash will be larger and noise will be louder.

NOTICE

If the timing gear teeth's surface is damaged by damping, or if any tooth lack of material, the timing gear shall be replaced with a new one.

If one timing gear should be replaced, it is better to replace the whole pair of gears, so that good mating surfaces can be guaranteed.

4-6. Crankcase cover and speed governor

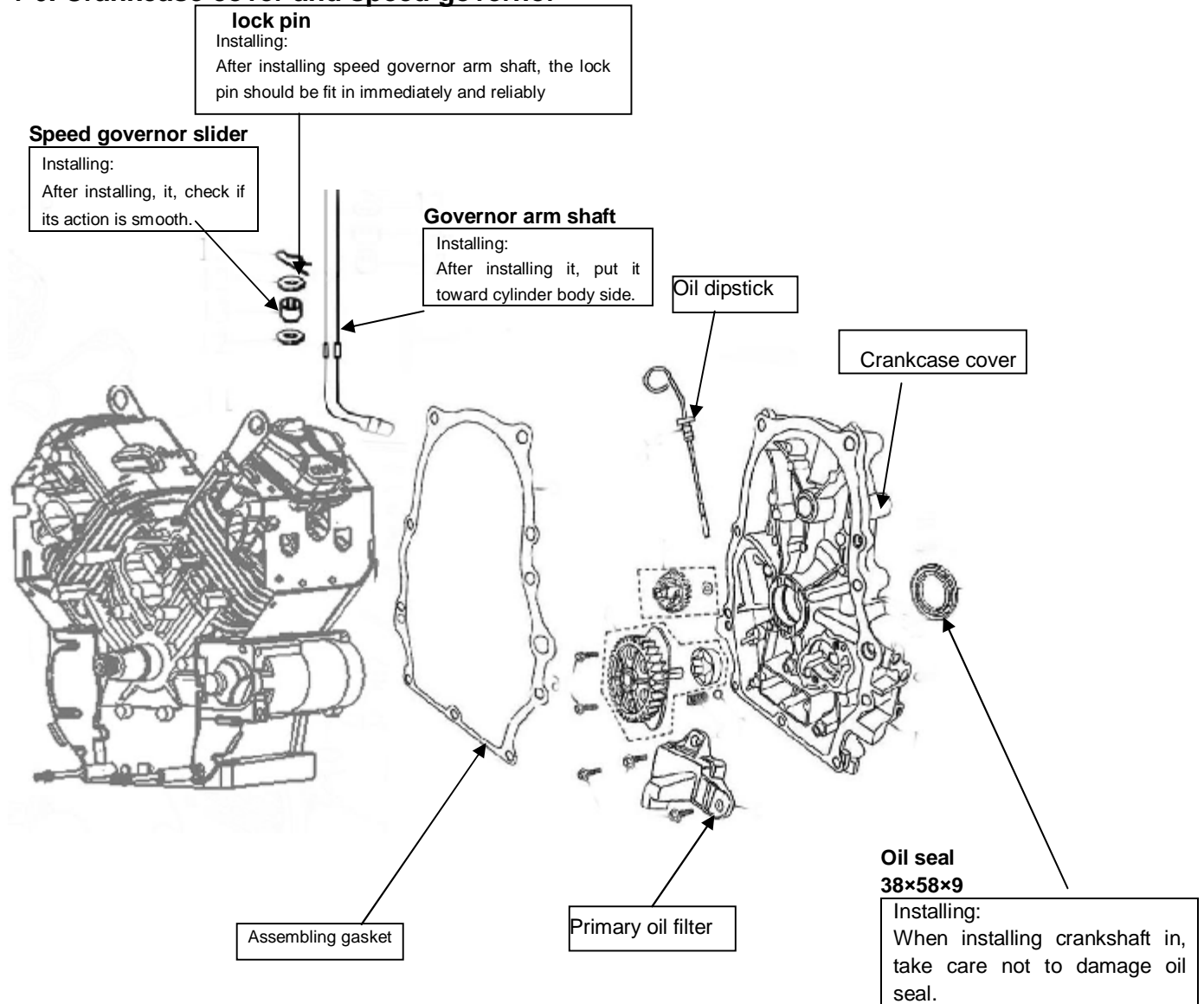

4-7. Flywheel, ignition coil and starter motor

a. Disassembling and assembling

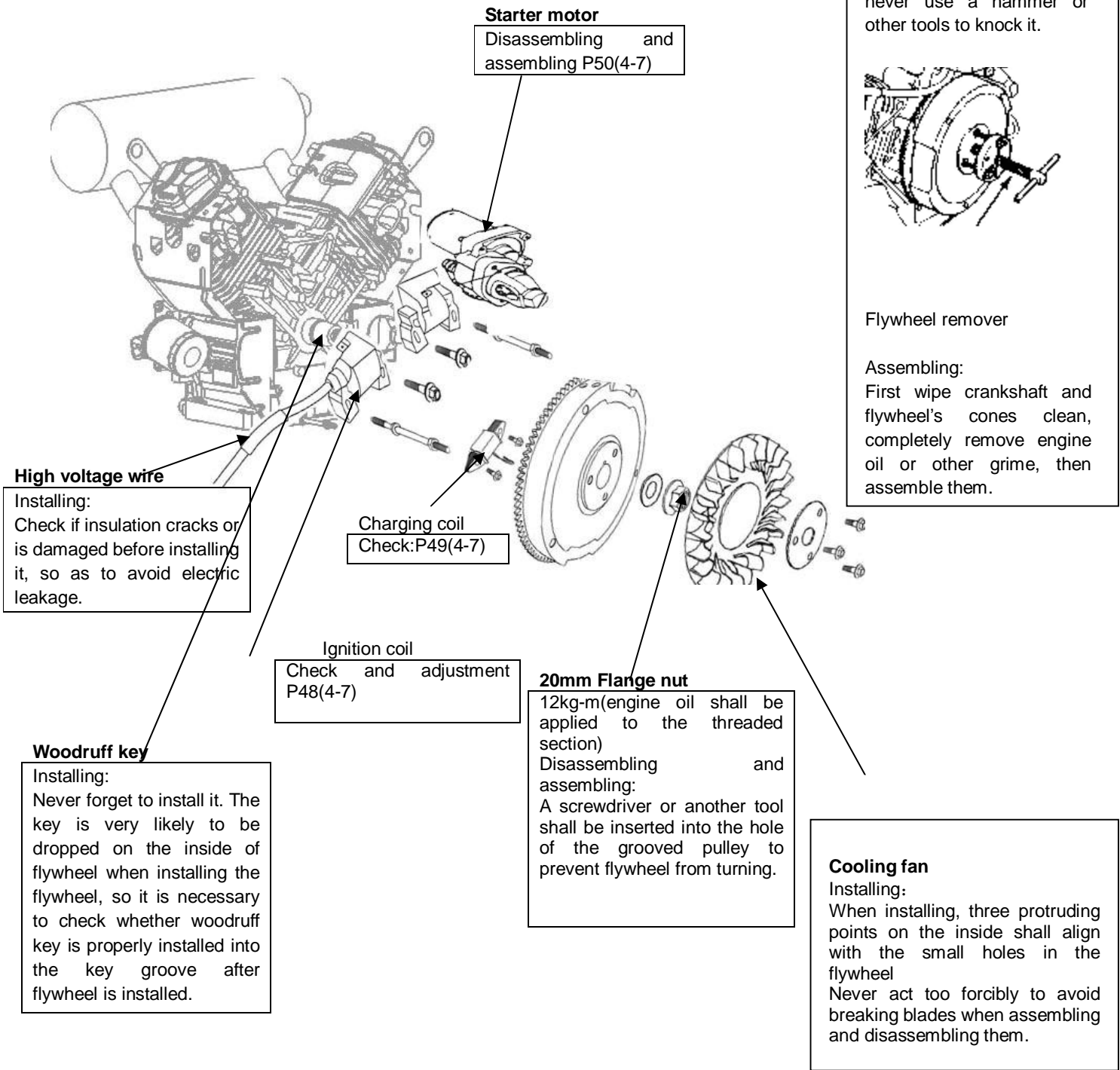

b. Adjustment of clearance between ignition coil and flywheel

1) Put the feeler gauge into the clearance between ignition coil and flywheel, or insert a piece of paper as thick as a postcard between the flywheel's outer rim and the ignition coil.

2) Press the ignition coil onto the flywheel with hands, tighten the bolts.

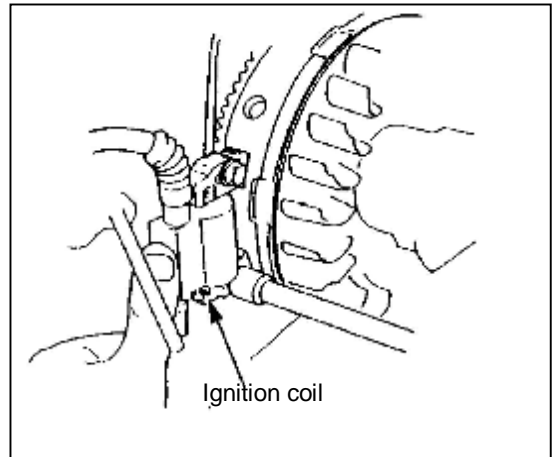

Prescribed clearance	0.4±0.2mm
----------------------	-----------

- Avoid the flywheel's magnet when adjusting.
- In order to ensure clearances on both ends of the ignition coil are equal, adjustment shall be made while the feeler gauge is inserted between flywheel's outer rim and the ignition coil.

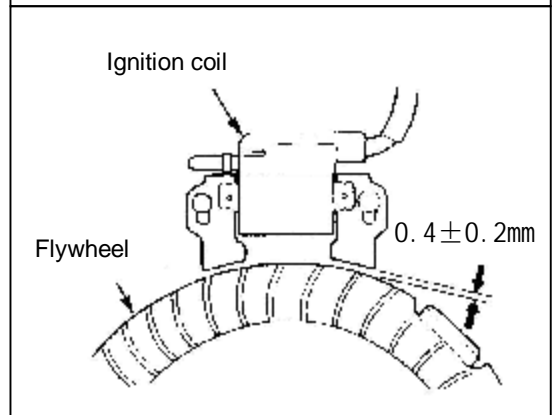

c. Check of ignition coil and charging coil

● Ignition coil

<Primary side's electric resistance>

Insert the tester's terminal between wire's terminal and the coil's iron core to measure the electric resistance on the primary side of the ignition coil.

Electric resistance	1.0~1.2Ω
---------------------	----------

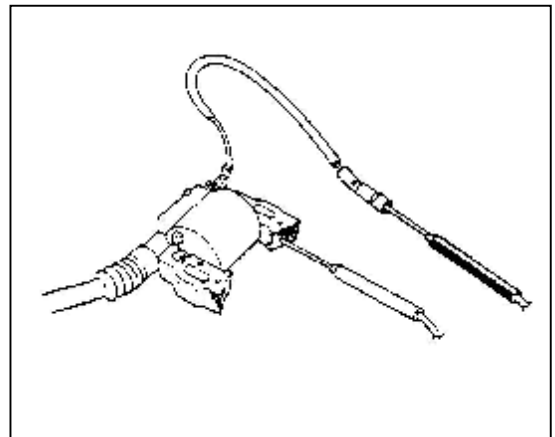

<Secondary side's electric resistance>

Insert the tester's terminal between the ignition coil's iron core and the high-voltage wire without spark plug cap to measure electric resistance on the secondary side of the ignition coil.

Electric resistance	5.9 ~ 7.1KΩ
---------------------	-------------

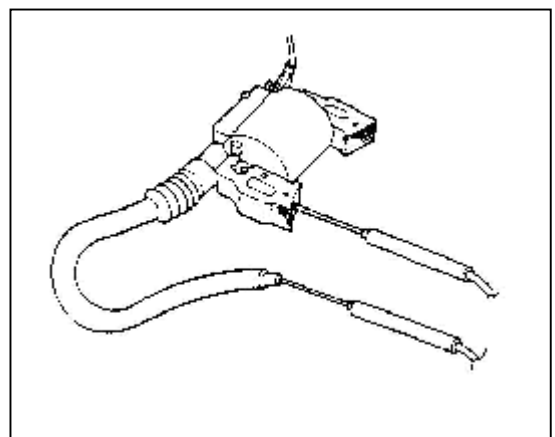

●Charging coil

Measure the electric resistance between the two terminals.

Electric resistance	$3.5\pm 0.5\Omega$
---------------------	--------------------

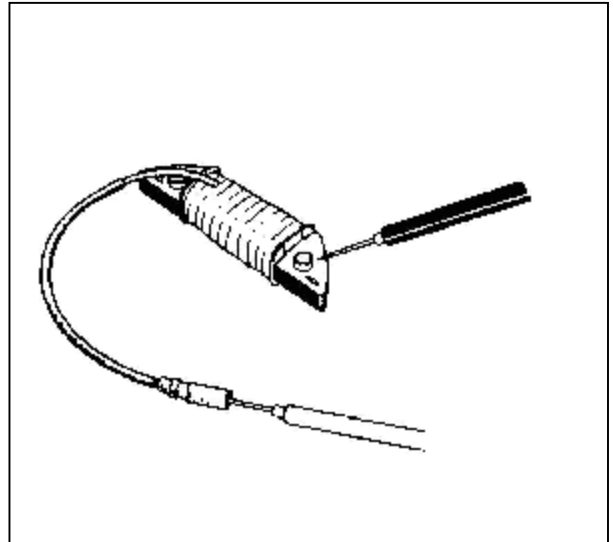

d. Check of starter motor

●Electromagnetic relay

Disconnect the battery's negative terminal. Disconnect the S terminal's plug from the electromagnetic relay, connect a 12V battery between starter terminal and the engine body, follow the method shown in the drawing to check continuity using a tester.

If the continuity is confirmed when the battery is connected, and not found when the battery is disconnected, it means the electromagnetic relay's continuity is normal.

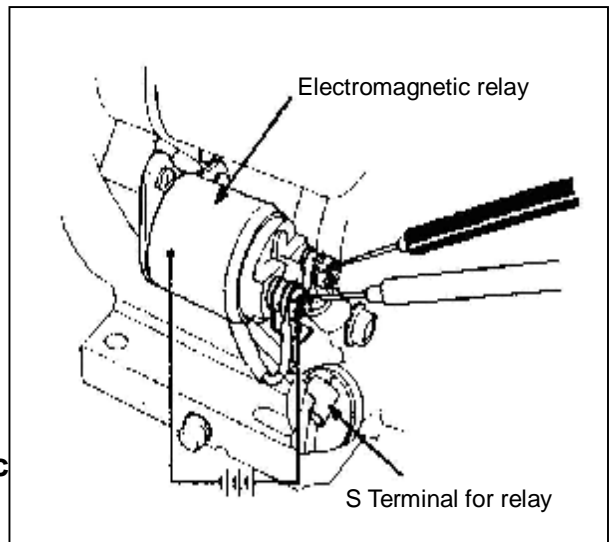

LONCIN INDUSTRIES, LTD.
Address: 99 Hualong Road, Jiulongpo District,
Chongqing 400052, China
Phone: 86 23 89067577/89067266
Fax: 86 23 89067533
Website: www.loncinengine.com
E-mail: marketing@loncinengine.com